

National Standard for Commercial Vessels

Part C Design and construction

Subsection 7A Safety equipment

Edition 3.9

This edition 3.9 was prepared by the Australian Maritime Safety Authority to incorporate the NSCV Omnibus amendments instrument No.1, 2022.

NSCV Omnibus amendments instrument No. 1, 2022 was approved by the National Marine Safety Regulator on 6 September 2022 and endorsed by the Infrastructure and Transport Ministers on 11 November 2022.

This edition 3.9 commences on 1 January 2023.

Published by Australian Maritime Safety Authority, GPO Box 2181 Canberra, ACT 2601.

Copyright



© Australian Maritime Safety Authority 2022

The Australian Maritime Safety Authority encourages the dissemination and exchange of information provided in this publication.

Except as otherwise specified, all material presented in this publication is provided under Creative Commons Attribution 4.0 International licence. This excludes:

- the Commonwealth Coat of Arms
- this Authority's logo
- content supplied by third parties.

The Creative Commons Attribution 4.0 International Licence is a standard form licence agreement that allows you to copy, distribute, transmit and adapt this publication provided that you attribute the work.

The details of the version 4.0 of the licence are available on the Creative Commons website, as is the full legal code for that licence.

Attribution

The Australian Maritime Safety Authority's preference is that you attribute this publication (and any material sourced from it) using the following wording:

Source:

© Australian Maritime Safety Authority, *National Standard for Commercial Vessels, Part C – Design and Construction, Subsection 7A - Safety equipment*

More information

For inquiries regarding copyright including requests to use material in a way that is beyond the scope of the terms of use that apply to it, please contact us.

Disclaimer

Australian Maritime Safety Authority accepts no liability for the accuracy of the information nor its use or the reliance placed on it.

FOREWORD

This Subsection of the National Standard for Commercial Vessels (NSCV) was developed following a review of the Uniform Shipping Laws (USL) Code to replace Section 10: Life Saving Appliances and part of Section 13: Miscellaneous Equipment of the USL Code.

In reviewing the USL Code and preparing this Subsection, consideration was given to a number of factors including:

- a) The National Marine Safety Strategy.
- b) Current designs, practices and materials.
- c) Coronal reports and incident investigations.
- d) Relevant national and international standards.
- e) Provisions no longer used.
- f) Current survey practice, both formal and informal.
- g) Discretionary requirements that rely on authority approval.
- h) Current technical standards format and style.

CONTENTS

CHAPTER 1	PRELIMINARY	8
1.1	Scope	8
1.2	Application.....	8
1.3	Objective	8
1.4	Referenced documents	8
1.5	Definitions	10
1.6	Abbreviations.....	11
CHAPTER 2	SAFETY EQUIPMENT OUTCOMES AND SOLUTIONS	12
2.1	Scope.....	12
	Required outcomes.....	12
2.2	Type and quantity.....	12
2.3	Performance of safety equipment.....	12
2.4	Availability	12
2.5	Effectiveness and reliability of safety equipment.....	12
2.6	Quality of service.....	12
2.7	Performance of the arrangements for deploying and boarding safety equipment	13
2.8	Reliability of the arrangements for deploying and boarding safety equipment	13
2.9	Operating instructions.....	13
2.10	Search and rescue	13
2.11	Identification	13
2.12	Evacuation	13
2.13	Means of rescue for persons overboard	13
2.14	Means to communicate distress and location	13
2.15	On board communications and alarm systems	13
2.16	Emergency electrical equipment.....	13
2.17	First aid	14
2.18	Means to sustain and prolong life of evacuees	14
2.19	Means to protect rescue crews.....	14
	Deemed-to-satisfy solutions.....	14
2.20	Compliance	14
	Equivalent solutions.....	14
2.21	Assessment methods	14
CHAPTER 3	SAFETY EQUIPMENT DESIGN AND CONSTRUCTION	15
3.1	Scope.....	15

	3.2	Objective	15
	3.3	Standards for safety equipment.....	15
CHAPTER 4		INSTALLATION OF SAFETY EQUIPMENT	17
	4.1	Scope.....	17
	4.2	Objective	17
	4.3	General requirements.....	17
	4.4	Lifeboats and rescue boats.....	18
	4.5	Liferafts	19
	4.6	Dinghies	20
	4.7	Buoyant appliances	21
	4.8	Lifebuoys.....	21
	4.9	Lifejackets	22
	4.10	Pyrotechnic and smoke signals	22
CHAPTER 5		TYPE AND QUANTITY OF SAFETY EQUIPMENT	23
	5.1	Scope.....	23
	5.2	Objective	23
	5.3	Safety equipment to be carried.....	23
	5.4	Open reversible liferafts.....	23
CHAPTER 6		SERVICING OF SAFETY EQUIPMENT	31
	6.1	Scope.....	31
	6.2	Objective	31
	6.3	Assessment methods	31
	6.4	Inflatable Coastal and open reversible liferafts	31
	6.5	Marine evacuation systems	31
	6.6	Inflatable lifejackets	32
	6.7	Inflatable non-SOLAS rescue boats.....	32
	6.8	Hydrostatic release units	32
	6.9	Launching appliances.....	32
	6.10	EPIRBs.....	32
	6.11	Pyrotechnic and smoke signals – period of validity	32
ANNEX A		REQUIREMENTS FOR SOLAS EQUIPMENT	33
	A1	Scope.....	33
	A2	General	33
ANNEX B		REQUIREMENTS FOR NON-SOLAS RESCUE BOATS.....	34
	B1	Scope.....	34
	B2	Design and construction	34
	B3	Fittings.....	34
	B4	Equipment	35

	B5	Marking of rescue boats	35
ANNEX C		REQUIREMENTS FOR DINGHIES	36
	C1	Scope	36
	C2	Design and construction	36
	C3	Fittings.....	36
	C4	Equipment	36
	C5	Marking	37
ANNEX D		REQUIREMENTS FOR INFLATABLE COASTAL LIFERAFTS.....	38
	D1	Scope	38
	D2	Design and construction	38
	D3	Equipment and rations.....	38
	D4	Stowage and launching	38
	D5	Marking	39
	D6	Servicing	39
ANNEX E		REQUIREMENTS FOR OPEN REVERSIBLE LIFERAFTS	40
	E1	Scope	40
	E2	Design and construction	40
	E3	Fittings.....	40
ANNEX F		REQUIREMENTS FOR BUOYANT APPLIANCES	42
	F1	Scope	42
	F2	Design and construction	42
	F3	Launching.....	43
	F4	Marking	43
ANNEX G		REQUIREMENTS FOR COASTAL LIFEJACKETS	45
	G1	Scope	45
	G2	Design and construction	45
ANNEX H		REQUIREMENTS FOR MEDICAL SUPPLIES	46
	H1	Scope	46
	H2	Objective	46
	H3	General	46
	H4	Carriage of dangerous goods	47
	H5	Expiry dates.....	47
	H6	Replacement of stocks	47
	H7	Labelling and packaging.....	47
	H8	Medical log book	48
	H9	First aid kit.....	48
	H10	Medical cabinet	48
	H11	First aid training.....	49
ANNEX I		TRANSITIONAL ARRANGEMENTS FOR EXISTING VESSELS.....	55

I1	Scope.....	55
I2	Objective	55
I3	Replacement safety equipment	55
I4	General provisions.....	55
I5	Equivalent requirements to apply.....	56

CHAPTER 1 PRELIMINARY

1.1 SCOPE

This Subsection of the NSCV specifies requirements for the design, manufacture, installation, stowage, marking and scale of safety equipment to be carried on vessels.

Chapter 2 deals with the required outcomes and solutions for safety equipment. Chapters 3 through to 6 specify the deemed-to-satisfy solutions for design and manufacture, installation, type and quantity to be carried, and servicing respectively, while Annexes A to H provide further detail on the standards to be met for certain items of safety equipment.

Annex I provides transitional arrangements, including timeframes for compliance, with the deemed-to-satisfy solutions specified in Chapters 3 to 6 and Annexes A to H, for 'existing vessels' as defined in *Marine Order 503 (Certificates of survey – National Law) 2017*.

This Subsection of the NSCV shall be read in conjunction with Part B—General Requirements of the NSCV

NOTE: Annex I provides transitional arrangements for existing vessels, as defined in *Marine Order 503 (Certificates of survey – National Law) 2017*, that are required to comply with this Subsection from 1 January 2018.

1.2 APPLICATION

This Subsection applies to each domestic commercial vessel that is required to comply with the NSCV by the National Law or its subordinate instruments, except:

- a) special vessels as defined in Part F of the NSCV must comply with Part F and are not required to comply with this Subsection unless Part F specifies otherwise; and
- b) non-survey vessels as defined in Part G of the NSCV must comply with Part G and are not required to comply with this Subsection unless Part G specifies otherwise.

NOTE: It is a condition of *Marine Order 503 (Certificates of survey) 2017* that new and existing vessels which are required to hold a certificate of survey must comply with the NSCV.

1.3 OBJECTIVE

The objective of this Subsection is to minimise the consequences of accidents by providing vessels with certain key items of safety equipment.

NOTES:

1. Hazards associated with design and construction failures of safety equipment include: failure to properly deploy, fit or operate, failure to perform safety function in immediate aftermath, failure to perform safety function over the likely period till rescue.
2. Consequences arising from these hazards include: inability to evacuate vessel in a timely manner, delay in or failure to rescue, personal injury and fatalities.

1.4 REFERENCED DOCUMENTS

The following documents are referred to in this Subsection.

Any document referenced in this Subsection should be considered to be the latest revision of the document including amendments.

TRANSPORT AND INFRASTRUCTURE COUNCIL

National Standard for Commercial Vessels

Part B—General Requirements

Part C—Design and Construction

Section 3: Construction

Section 4: Fire Safety

Section 5: Engineering

Subsection 5B—Electrical

Section 6: Stability

Subsection 6A—Intact stability requirements

Subsection 6B—Buoyancy and stability after flooding

Section 7: Equipment

Subsection 7B—Communications equipment

STANDARDS AUSTRALIA

AS 1499—*Personal flotation devices—Type 2*

AS 1799.1—*Small Pleasure Boats Code – Part 1 General requirements for power boats*

AS 2092—*Pyrotechnic marine distress flares and signals for pleasure craft*

AS 2677—*Inflatable boats*

AS 2700—*Colour Standards for general purposes*

AS/NZS 4280.2—*406 MHz satellite distress beacons – Personal locator beacons (PLBs)*

AS 4758.1—*Personal flotation devices—Part 1: General requirements*

BRITISH STANDARDS

BS EN 396—*Lifejackets and personal buoyancy aids. Lifejacket 150*

INTERNATIONAL MARITIME ORGANIZATION

International Code of Safety for High-Speed Craft, 2000 (also known as the 2000 HSC Code)

International Life-Saving Appliance Code adopted by IMO Resolution MSC.48 (66), as in force from time to time (also known as the LSA Code)

International Maritime Dangerous Goods Code (also known as the IMDG Code)

IMO Resolution MSC.81(70) Revised Recommendation on Testing of Life-Saving Appliances

IMO Resolution A.760(18) Symbols related to life-saving appliances and arrangements

INTERNATIONAL ORGANIZATION FOR STANDARDIZATION

ISO 9650-1—*Small craft — Inflatable liferafts — Part 1: Type I*

ISO 12402-3—*Personal flotation devices—Part 3: Lifejackets, performance level 150 — Safety requirements*

AUSTRALIAN MARITIME SAFETY AUTHORITY

Marine Order 11 (Living and working conditions on vessels) 2013

Marine Order 25 (Equipment — life-saving) 2014

Marine Order 27 (Safety of navigation and radio equipment) 2016

Marine Order 503 (Certificates of survey – national law) 2018 (Marine Order 503)

Marine Order 504 (Certificates of operation and operation requirements — national law) 2018 (Marine Order 504)

Marine Order 505 (Certificates of competency – national law) 2022 (Marine Order 505)

EUROPEAN UNION

EU Marine Equipment Directive, Module B (MED-B)

HER MAJESTY'S STATIONERY OFFICE (HMSO)

Ship Captain's Medical Guide

1.5

DEFINITIONS

For the purpose of this Subsection of the NSCV—

- a) the definitions provided in Part B of the NSCV and those in this Clause shall apply unless otherwise indicated; and
- b) where there is any conflict in the terms defined between this Clause and Part B, the definitions in this Clause shall apply.

buoyant appliance—

a device designed to assist a person to float in water.

class 3 EPIRB—

an EPIRB that has a manual activation switch only.

complement—

the maximum number of crew and passengers the vessel is permitted to carry for its service category in compliance with the whole of the NSCV (see NSCV Part B where concurrent operations are carried out by the vessel).

high-risk space—

as defined in NSCV Part C Section 4.

highly visible colour—

any one of the following colours:

- a) as defined in AS 2700:
 - i) X 15 — Orange;
 - ii) R 11 — International Orange;
 - iii) R 12 — Scarlet;
 - iv) Y14 — golden yellow; or
- b) as defined in the British Standard 381C:1996, Ref 368:
 - i) ref 386 — traffic yellow;
 - ii) ref 592 — international orange; or
- c) a colour of equivalent conspicuity recognised in an Australian standard, ISO standard, IMO standard or UK Merchant Shipping Notice for the purposes of use in marine safety equipment.

level flotation—

a flotation system that will keep a boat carrying its maximum load from sinking when swamped, assuming the occupants remain within the boat and supported by the flotation system. The flotation system must be such that it will keep the swamped boat floating level, and prevent it from capsizing in calm water. Level flotation does not provide a self-righting capacity.

remote enclosed waters—

waterways where assistance from shore based facilities or other vessels is not readily available and where rescue services would likely be required in the event of an emergency.

survival craft—

a craft capable of sustaining the lives of persons in distress from the time of abandoning the vessel. It includes a lifeboat, rescue boat, liferaft, buoyant appliance and dinghy.

1.6

ABBREVIATIONS**AMSA—**

Australian Maritime Safety Authority

BS—

British Standard

EPIRB—

Emergency position indicating radio beacon

EU—

European Union

HSC—

High speed craft

ISO—

International Organization for Standardization

JAS-ANZ—

Joint Accreditation Scheme - Australia and New Zealand

MES—

Marine evacuation system

PFD—

Personal flotation device

PLB—

Personal locator beacon

CHAPTER 2 SAFETY EQUIPMENT OUTCOMES AND SOLUTIONS

2.1 SCOPE

This Chapter specifies the required outcomes for safety equipment and the corresponding requirements for deemed-to-satisfy and equivalent solutions. The required outcomes are mandatory to the extent that they are applicable to a vessel in the relevant deemed-to-satisfy solutions.

Chapters 3 to 6 and Annexes A to H set out the deemed-to-satisfy solutions for meeting the required outcomes mentioned in this chapter.

Annex I provides transitional arrangements, including timeframes for compliance, with the deemed-to-satisfy solutions specified in Chapters 3 to 6 and Annexes A to H, for 'existing vessels' as defined in *Marine Order 503 (Certificates of survey – National Law) 2017*.

Compliance with the required outcomes may also be achieved through the application of an approved equivalent means of compliance (equivalent solution).

NOTE 1: Annex I provides transitional arrangements for existing vessels, as defined in *Marine Order 503 (Certificates of survey – National Law) 2017*, that are required to comply with this Subsection from 1 January 2018.

NOTE 2: See *Marine Order 503 (Certificates of survey – national law) 2017* for the criteria for making an application to the National Regulator to seek approval of an equivalent means of compliance.

REQUIRED OUTCOMES

2.2 TYPE AND QUANTITY

A vessel must be provided with safety equipment of type and quantity appropriate to control to acceptable levels the risks associated with the operation of the vessel, taking into account its area of operation and the number of persons on board as well as other risk factors that might be relevant.

2.3 PERFORMANCE OF SAFETY EQUIPMENT

Safety equipment must be designed, constructed and arranged to function so as to significantly enhance the probability of survival in the event of an incident.

2.4 AVAILABILITY

Safety equipment must be located, and storage space clearly marked, so as to be readily available for its purpose in the event of an incident.

2.5 EFFECTIVENESS AND RELIABILITY OF SAFETY EQUIPMENT

Safety equipment must be designed, constructed, arranged and maintained so as to function effectively and reliably at time of need over the life of the vessel.

NOTE: Arrangements for the servicing of liferafts and other lifesaving equipment that effectively maintains compliance of the equipment with the standard over time are evidence of compliance with this required outcome.

2.6 QUALITY OF SERVICE

Persons or organisations engaged in the servicing of safety equipment must be organised to provide appropriate levels of quality in servicing outcomes that are capable of being verified.

2.7 PERFORMANCE OF THE ARRANGEMENTS FOR DEPLOYING AND BOARDING SAFETY EQUIPMENT

Safety equipment must be installed and arranged to facilitate its operation and deployment in a safe and timely manner during emergency conditions, by day or by night.

2.8 RELIABILITY OF THE ARRANGEMENTS FOR DEPLOYING AND BOARDING SAFETY EQUIPMENT

Arrangements for deploying and boarding safety equipment must be designed, constructed and maintained so as to function reliably and safely during emergency conditions at all times.

2.9 OPERATING INSTRUCTIONS

Persons must be provided with sufficient information and knowledge to enable them to effectively use all available safety equipment at time of need.

2.10 SEARCH AND RESCUE

Arrangements must be provided such that safety equipment facilitates search and rescue operations at all times during daylight and at night.

2.11 IDENTIFICATION

Measures must be provided to facilitate rapid identification of the parent vessel to which safety equipment was fitted should an incident occur.

2.12 EVACUATION

Arrangements must be provided to enable rapid evacuation of the vessel by all persons on the vessel at all times for the range of environmental conditions likely to be encountered.

2.13 MEANS OF RESCUE FOR PERSONS OVERBOARD

Means must be provided to enable the survival and rapid rescue of persons overboard.

NOTE: See also Marine Order 504 in relation to Man Overboard procedures.

2.14 MEANS TO COMMUNICATE DISTRESS AND LOCATION

More than one reliable means must be provided to communicate distress and location to other vessels, aircraft and the shore in order to initiate and facilitate rapid rescue.

2.15 ON BOARD COMMUNICATIONS AND ALARM SYSTEMS

Arrangements must be provided for alerting persons on the vessel of imminent danger, summoning persons to assembly stations and initiating the actions included in the emergency plan.

NOTE: Marine Order 504 contains requirements for emergency planning.

2.16 EMERGENCY ELECTRICAL EQUIPMENT

Electrical power essential for the safety of the vessel and persons on board must be maintained during emergency situations for a period sufficient for the emergency to be overcome or evacuation of the vessel.

2.17 FIRST AID

Sufficient and appropriate medical supplies must be maintained to treat likely individual injuries until professional medical treatment becomes available.

NOTE: Factors that should be taken into account include the proximity of shore-based health services, operation within areas served by helicopters and the medical training of persons on the vessel.

2.18 MEANS TO SUSTAIN AND PROLONG LIFE OF EVACUEES

Survival equipment must be arranged and equipped to protect the health and safety of evacuees in the event that rescue is delayed.

2.19 MEANS TO PROTECT RESCUE CREWS

Persons exposed to risks of hypothermia associated with the rescue of others must have a means available to control those risks to an acceptable level.

DEEMED-TO-SATISFY SOLUTIONS**2.20 COMPLIANCE**

For the purpose of this National Standard, safety equipment shall be deemed-to-satisfy the Required Outcomes in Clauses 2.2 to 2.19 to the extent specified by this Subsection if it complies with the relevant provisions of Chapter 3 to Chapter 6.

EQUIVALENT SOLUTIONS**2.21 ASSESSMENT METHODS**

Equivalent solutions applicable to safety equipment shall be verified in a manner appropriate to the risks that would arise should the equipment fail to perform at time of need.

NOTE: Assessment methods applicable to systems of safety equipment tend to be rigorous to promote reliability of performance. Special diligence is needed to avoid the possibility of insufficient or inappropriate equipment being provided at time of need. In addition to the need for rigorous assessment, options for equivalent solutions may be limited by enabling legislation.

CHAPTER 3 SAFETY EQUIPMENT DESIGN AND CONSTRUCTION

3.1 SCOPE

This Chapter specifies the requirements for the design and construction of safety equipment.

3.2 OBJECTIVE

The objective of this chapter is to ensure that safety equipment to be carried on board a vessel is suitable for the purpose for which it is to be used.

3.3 STANDARDS FOR SAFETY EQUIPMENT

3.3.1 Specification

The items of safety equipment specified in column 1 of Table 1 shall comply with the applicable Annex of this Subsection or the standard specified in column 2 of Table 1.

3.3.2 Assessment and verification

Safety equipment shall be assessed and verified as meeting the applicable specification by one or more of the following methods:

- a) Tested and specifically listed for the purpose by a recognised testing and listing organisation in Australia.
- b) Certified by a JAS-ANZ accredited product certification body.
- c) Type approved by a ship classification society recognised by the Australian Maritime Safety Authority (AMSA).
- d) Certified by an AMSA-recognised Notified Body in accordance with the EU Marine Equipment Directive, Module B (MED-B).

Testing and listing, certification or type approval in the foregoing manner shall be deemed to be proof of compliance with the relevant standard or Annex of this Subsection.

Table 1 — Construction, production and performance requirements for safety equipment

Item of equipment	Annex or standard to which item shall comply
Anti-exposure suit [SOLAS]	Annex A
Buoyant appliance	Annex F
Buoyant smoke signal [SOLAS]	Annex A
Dinghy	Annex C
EPIRB, 406 MHz [SOLAS]	Annex A
Flare – hand held (includes red hand held flares, orange hand held smoke signals)	AS 2092, Annex A
Flare – rocket parachute (includes parachute distress rockets and rocket parachute flare)	AS 2092, Annex A
General emergency alarm system	Annex A
Launching appliance [SOLAS]	Annex A
Lifeboat [SOLAS]	Annex A
Lifebuoy [SOLAS]	Annex A
Lifejacket [SOLAS]	Annex A
Lifejacket [Coastal]	Annex G
Lifejacket light	Annex A
Liferaft (inflatable) [SOLAS]	Annex A
Liferaft (inflatable) [Coastal]	Annex D
Liferaft (open reversible)	Annex E
Line-throwing appliance [SOLAS]	Annex A
Marine evacuation system [SOLAS]	Annex A
Personal Flotation Device Type 2	AS 1499, AS 4758.1 Level 50
Public address system	Annex A
Rescue boat [SOLAS]	Annex A
Rescue boat [Non-SOLAS]	Annex B
Self-activating smoke signal [SOLAS]	Annex A
Self-igniting light [SOLAS]	Annex A
Thermal protective aid [SOLAS]	Annex A

CHAPTER 4 INSTALLATION OF SAFETY EQUIPMENT

4.1 SCOPE

This Chapter specifies requirements for the installation of safety equipment on board vessels including the arrangements for stowage, labelling and launching.

4.2 OBJECTIVE

The objective of this Chapter is to ensure that all safety equipment on a vessel is readily accessible, identified and maintained in optimum operating condition.

4.3 GENERAL REQUIREMENTS

4.3.1 Stowage of safety equipment

4.3.1.1 *SOLAS life-saving appliances*

SOLAS life-saving appliances on class A vessels shall be stowed in accordance with the requirements specified in *Marine Order 25 (Equipment — life-saving) 2014* for class A vessels over 500 gross tonnage.

4.3.1.2 *Stowage above high-risk spaces*

Safety equipment (including lifejackets) shall not be stowed directly above a machinery space or other high-risk space, unless the deck in that area is protected in accordance with NSCV Part C, Section 4.

4.3.1.3 *Marking of stowage locations*

Unless the equipment is visible, stowage locations for safety equipment shall be marked, indicating the devices stowed in that location for that purpose. If more than one device is stowed in that location, the number of devices shall also be indicated.

NOTE: Symbols used should conform to IMO Resolution A.760(18) Symbols Related to Life-saving Appliances and Arrangements

4.3.2 Embarkation into survival craft

4.3.2.1 *Means of embarkation*

A means of embarkation into survival craft shall be provided at each embarkation point where the freeboard between the intended embarkation point and the waterline is more than 1.5 m.

Where fitted, the means of embarkation shall be long enough to reach the survival craft when afloat at the vessel's lightest sea-going draft with an adverse trim of 10° and list of 15°.

4.3.2.2 *Additional requirements for embarkation ladders*

Where embarkation ladders are fitted, handholds, rails or stanchions shall be provided to ensure a safe passage from the deck to head of the ladder and vice-versa.

Embarkation ladders shall comply with *Marine Order 25 (Equipment — life-saving) 2014*, or another relevant national or international standard.

4.3.2.3 *Marine evacuation systems*

Where fitted, marine evacuation systems (MES) shall comply with the requirements specified in *Marine Order Part 25 (Equipment — life-saving) 2014* for class A vessels over 500 gross tonnage.

4.3.2.4 **Overboard discharges**

Means shall be provided to prevent any overboard discharge on to a survival craft during abandonment.

4.4 **LIFEBOATS AND RESCUE BOATS**

4.4.1 **Parent vessel identification**

In addition to the requirements for marking contained in *Marine Order 25 (Equipment — life-saving) 2014* and Annex B of this Subsection, as applicable, the lifeboat or rescue boat shall have the parent vessel's identification legibly and permanently marked on each side of the bow in figures not less than 75 mm in height in contrasting colours.

NOTE: Identification may include the registration number, name of vessel, home port or other form of identification required by an Authority on the parent vessel.

4.4.2 **Stowage of lifeboats and rescue boats**

Lifeboats and SOLAS rescue boats shall be stowed in accordance with the requirements specified in *Marine Order 25 (Equipment — life-saving) 2014* for class A vessels over 500 gross tonnage.

Non-SOLAS rescue boats shall be stowed such that they—

- a) are ready for immediate deployment (Inflatable rescue boats shall be kept inflated at all times);
- b) are capable of being safely deployed within 5 minutes with a vessel trim of 10° and a list of 15° either way;
- c) do not impede the safe deployment of other survival craft;
- d) do not impede the marshalling of passengers to their assembly stations and their embarkation into other survival craft; and
- e) allow launching to take place down the side of the vessel

NOTE: This is specified to minimise the difficulty in launching, to minimise the possibility of persons in the survival craft being thrown from the survival craft and to minimise the possibility of the moving vessel striking the survival craft.

Non-SOLAS rescue boats shall not be stowed or launched from any of the following positions:

- i) Forward of the collision bulkhead.
- ii) Where damage from the elements may occur.
- iii) On or above cargo tanks on tankers; slop tanks; or other tanks containing explosive or hazardous cargoes.
- iv) Near the steeply overhanging portions of the hull aft.
- v) That would result in the rescue boat being in the vicinity of the vessel's propeller or other propulsive device when lowered.

4.4.3 **Launching and retrieval**

Means of launching and recovering lifeboats and SOLAS rescue boats shall be in accordance with the requirements specified in *Marine Order 25 (Equipment — life-saving) 2014* for class A vessels over 500 gross tonnage.

Where a non-SOLAS rescue boat is carried, the parent vessel shall be fitted with a safe means of launching and recovering the rescue boat. Such means shall be capable of launching and recovering the rescue boat when loaded with two (2) persons (each assumed to be of 80 kg weight) and its full outfit of equipment.

Structural members and all blocks, falls, padeyes, links, fastenings and all other fittings used in connection with launching equipment shall be designed with a factor of safety on the basis of maximum working load assigned and the ultimate strength of the material used for construction. A minimum factor of safety of 4.5 shall be applied to all structural members, and a minimum factor of safety of 6 shall be applied to falls, suspension chains, links and blocks.

4.4.4 Illumination

Means shall be provided to ensure that lifeboats, rescue boats, their associated launching devices, and the area of water into which they will be deployed, shall be sufficiently illuminated during assembly, embarkation, launching and retrieval in accordance with the requirements for Emergency Electrical Installations in NSCV Part C, Subsection 5B.

4.4.5 Operating instructions

Posters or signs shall be provided on, or in the vicinity of lifeboats, rescue boats, their launching controls and shall—

- a) illustrate the purpose of controls and the procedures for operating the appliance and give relevant instructions or warnings; and
- b) be easily seen under emergency lighting conditions.

NOTE: Symbols used should conform to IMO Resolution A.760(18) Symbols Related to Life-saving Appliances and Arrangements.

4.5 LIFERAFTS

4.5.1 Appropriate vessel identification

In addition to the requirements for marking contained in Annex A, Annex D, and Annex E of this Subsection, a liferaft shall be legibly marked in contrasting colours in such a form that it can be changed at any time without opening the container with either:

- a) the parent vessel's identification; or
- b) the HexID or unique identification number (UIN) of the EPIRB that is fitted in the liferaft; or
- c) other appropriate identification to facilitate rapid identification of the parent vessel to which the life raft was fitted should an incident occur.

EXAMPLE of appropriate identification: operator's name.

4.5.2 Stowage of liferafts

Liferafts shall be stowed in accordance with the following:

- a) Each individual liferaft shall be in a state of continuous readiness so that 2 crew members can carry out launching within 5 minutes. All liferafts shall be safely launched within 30 minutes. This requirement applies when the vessel has up to 10° trim and 15° list either way.
- b) Liferafts shall be stowed—
 - i) with painters secured to the vessel by means of a hydrostatic release;
 - ii) so that each liferaft floats free and, where applicable, inflates automatically when the vessel sinks;
 - iii) in positions such that they float free if the vessel capsizes or sinks;

NOTE: Refer to manufacturer's recommendations on installation and location.

- iv) so as not to impede the safe deployment of other survival craft;
 - v) so as not to impede the marshalling of passengers to their assembly stations and their embarkation on other survival craft; and
 - vi) to facilitate launching down the side of the vessel.
- c) Liferafts intended for throw-overboard launching shall be stowed so as to be readily transferable for launching on either side of the vessel.
- d) On vessels where it is necessary, due to reduced freeboard; restricted deck space; vulnerability to heavy weather damage; or otherwise, to stow a liferaft inboard from the vessel's side, stowage shall be such that one person, with a minimum of physical effort, can effect launching.

Liferafts launched from fixed launching devices shall not be stowed or launched from any of the following positions:

- i) Forward of the collision bulkhead.
- ii) A position where damage from the elements may occur.
- iii) On or above cargo tanks on tankers; slop tanks; or other tanks containing explosive or hazardous cargoes.
- iv) Near the steeply overhanging portions of the hull aft.
- v) A position that would result in the liferaft being in the vicinity of the vessel's propeller or other propulsive device when lowered.

4.5.3 Illumination

Means shall be provided to ensure that the stowage positions of liferafts, the launching devices (where fixed launching devices are used), and the areas of water into which the liferafts will be deployed shall be sufficiently illuminated during assembly, embarkation, launching; and retrieval in accordance with the requirements for emergency electrical installations in NSCV Part C, Subsection 5B.

4.5.4 Operating instructions

Posters, signs or operating instructions shall be provided on, or in the vicinity of liferafts and their launching controls and shall—

- a) illustrate the purpose of controls and the procedures for operating the appliance and give relevant instructions or warnings; and
- b) be easily seen under emergency lighting conditions.

NOTE: Symbols used should conform to IMO Resolution A.760(18) Symbols Related to Life-saving Appliances and Arrangements.

4.6 DINGHIES

4.6.1 Parent vessel identification

In addition to the requirements for marking contained in Annex C, the dinghy shall have the parent vessel's identification legibly and permanently marked on the dinghy's transom in figures not less than 75 mm in height in contrasting colours.

NOTE: Identification may include the registration number, name of vessel, home port or other form of identification required by an Authority on the parent vessel.

4.6.2 Stowage of dinghies

Dinghies shall be stowed so that they—

- a) can be safely deployed from a vessel with up to 10° trim and 15° list either way;

- b) do not impede deployment of other survival craft; and
- c) are ready for immediate deployment.

4.6.3 Launching

- a) Where manual launching is not possible, a means of launching a dinghy with its full complement of equipment should be provided. Such means shall be capable of launching and recovering the dinghy when loaded with 2 persons (each assumed to be 80 kg weight) and its full outfit of equipment.
- b) The dinghy shall be provided with fittings that are compatible with the method of launching.

4.6.4 Illumination

Means shall be provided to ensure that the stowage positions of dinghies and the areas of water into which dinghies will be deployed shall be sufficiently illuminated during assembly, embarkation, launching and retrieval in accordance with the requirements for emergency electrical installations in Part C, Subsection 5B.

4.7 BUOYANT APPLIANCES

4.7.1 Parent vessel identification

In addition to the requirements for marking contained in Annex F, the buoyant appliance shall be marked with the parent vessel's identification on both of the largest faces of the appliance in legible and permanently marked figures not less than 75 mm in height in contrasting colours.

NOTE: Identification may include the registration number, name of vessel, home port or other form of identification required by an Authority on the parent vessel.

4.7.2 Stowage of buoyant equipment

Buoyant appliances shall be stowed in positions so that they—

- a) can be safely deployed from a vessel with up to 10° trim and 15° list either way;
- b) do not impede deployment of other survival craft; and
- c) float free if the vessel capsizes or sinks.

4.7.3 Illumination

Means shall be provided to ensure that the stowage positions of buoyant appliances and the areas of water into which they will be deployed shall be sufficiently illuminated during assembly; embarkation; launching and retrieval in accordance with the requirements for emergency: electrical installations in Part C, Subsection 5B.

4.8 LIFEBUOYS

4.8.1 Parent vessel identification

The identification of the vessel upon which the lifebuoy is stowed shall be legibly and permanently marked in figures not less than 75 mm in height in contrasting colours.

NOTE: Identification may include the registration number, name of vessel, home port or other form of identification required by an Authority on the parent vessel.

4.8.2 Stowage of lifebuoys

A lifebuoy shall be stowed so that it—

- a) is not permanently secured;

- b) is readily accessible to crew or passengers; and
- c) can be easily deployed.

Where two (2) lifebuoys with self-igniting lights and smoke signals are required, they shall be stowed to allow for immediate access and rapid deployment from the operating position.

4.9 LIFEJACKETS

4.9.1 Parent vessel marking

In addition to the requirements for marking contained in Annex G, the lifejacket shall have the parent vessel's identification legibly and permanently marked on the jacket in figures not less than 12 mm in height in contrasting colours.

NOTE: Identification may include the registration number, name of vessel, home port or other form of identification required by an Authority on the parent vessel.

4.9.2 Stowage of lifejackets

Lifejackets shall be stowed in clearly marked, easily located, and readily accessible stowage areas. The stowage areas shall be dry and protected from weather and excessive heat.

4.9.3 Stowage area information

At least one set of written and pictorial instructions for lifejacket use shall be exhibited at each location where the lifejackets are stowed.

4.10 PYROTECHNIC AND SMOKE SIGNALS

4.10.1 Stowage and marking

Pyrotechnic and smoke signals shall be stowed in a buoyant watertight container, fitted with a handle or lanyard. The container shall be clearly and permanently marked as to its contents.

On Class 1 and Class 2 vessels the container shall be readily accessible to the crew. On Class 3 vessels the container shall be mounted in a float free position and be readily accessible.

CHAPTER 5 TYPE AND QUANTITY OF SAFETY EQUIPMENT

5.1 SCOPE

This Chapter specifies the type and minimum quantity of safety equipment to be carried on board a vessel.

5.2 OBJECTIVE

The objective of this Chapter is to specify minimum standards for the type and quantity of safety equipment to be carried on a vessel appropriate for risks that are likely to be encountered.

5.3 SAFETY EQUIPMENT TO BE CARRIED

Class 1A, 2A, and 3A vessels shall comply with the provisions of *Marine Order 25 (Equipment — life-saving) 2014*.

All other vessels shall comply with Tables 2, 3 and 4 as applicable.

NOTES:

1. The requirements for the type and quantity of EPIRBs, other than those for use with inflatable coastal liferafts, are specified in NSCV Part C Subsection 7B.
2. In addition to carrying EPIRBs, the safety of crew members on Class 3 vessels will be enhanced by wearing PLBs complying with AS/NZS 4280.2 or the installation of an electronic man-overboard system when working in Operational Areas A, B or C. It should be noted that PLBs, like EPIRBs, must be registered; however PLB registration is to an individual and does not include vessel details. Details for the registration of PLBs are contained in AS/NZS 4280.2 or may be obtained from AMSA.
3. In addition to the equipment specified in this Subsection, Marine Order 504 may require that an operator demonstrate, through emergency plans or ship safety management processes, that the type and performance of safety equipment carried on board is appropriate to the specific vessel operations.
4. Factors to consider when satisfying Marine Order 504 may include, but are not limited to, type of vessel, geographical area of operation, prevailing weather conditions, ambient / sea temperatures, availability of rescue services, wildlife in the immediate vicinity, limitations of passengers, i.e. children, elderly and handicapped.

5.4 OPEN REVERSIBLE LIFERAFTS

5.4.1 Alternative arrangements for restricted offshore operations

Coastal liferafts may be replaced by open reversible inflatable liferafts for restricted offshore (class C) operations where the safety of crew and passengers would not be adversely affected. A risk assessment should take into account the following factors:

- a) Vessel size.
- b) Number of liferafts provided.
- c) Other safety equipment available.
- d) Number of crew and passengers.
- e) Sea state and likely weather conditions.
- f) Proximity to and suitability of rescue facilities.
- g) Time of year.
- h) Whether the vessel will be at sea during hours of darkness.

5.4.2 Alternative arrangements for sheltered waters

Open reversible liferafts of equivalent aggregate capacity may replace dinghies and buoyant appliances for vessels operating in sheltered waters.

Dinghies shall not under any circumstance replace open reversible liferafts. Buoyant appliances shall not under any circumstance replace open reversible liferafts or dinghies where dinghies are specifically required.

Table 2 — Scales of safety equipment for Class 1 vessels

Liferafts and rescue boats	Annex	1B	1C	1D	1E
Inflatable Coastal liferaft(s) for 100% complement and a non-SOLAS Rescue Boat (R1)	D / B	≥25 m		NA	NA
Inflatable Coastal liferaft for 100% complement	D	<25 m		NA	NA

KEY:

(R1) – On vessels continuously engaged on voyages in operational areas with a monthly mean water temperature of 15°C or less, an anti-exposure suit of an appropriate size shall be provided for every person assigned to crew the rescue boat.

Buoyant appliances (general)	Annex	1B	1C	1D	1E
A dinghy plus sufficient buoyant appliances, lifebuoys (B4) or both for 100% complement	C / F / A	NA	NA	≥25 m (B1)	NA
Sufficient buoyant appliances, lifebuoys (B4) or both for 100% complement	F / A	NA	NA	<25 m (B1, B2, B5)	NA
Sufficient buoyant appliances, lifebuoys (B4), dinghies or combination for 40% complement	F / A / C	NA	NA	NA	YES (B1, B3, B5)

KEY:

(B1) – For vessels operating in waters where it may be unsafe for persons to be immersed in the water, such as waters where the mean monthly water temperature is <15 degrees and waters which are infested with hazardous flora or fauna, a risk assessment must be conducted and documented in the safety management system for the vessel to determine whether open reversible liferafts of equivalent aggregate capacity should replace buoyant appliances. Liferafts must replace buoyant appliances on these vessels unless the risk assessment shows it is safe to use buoyant appliances and therefore have persons immersed in the water.

EXAMPLES of hazardous flora or fauna may include but are not limited to sharks, crocodiles or Irukandji jellyfish.

EXAMPLE of where it may be safe to use buoyant appliances may include a vessel operating in waters which can drop below 15 degrees for short periods where the vessel operates very close to shore and all persons on board the vessel would be rescued within a very short period of time in all circumstances.

(B2) – A dinghy may be included for rescue of persons overboard.

(B3) – Vessels conforming to Flooding Risk Category II as specified in NSCV Part C Section 6B, having a passenger limit of 36 day passengers —buoyant appliances for 100% complement.

(B4) – Each lifebuoy is assumed to provide support for two (2) persons.

(B5) – Vessels less than 25 m in measured length shall have suitable equipment on board to sustain and effectively recover persons overboard, e.g. heaving line with rescue quito, ladder, rescue sling, scramble net.

Lifebuoys	Annex	1B	1C	1D	1E
<u>12 x lifebuoys</u> : 4 with lights; 2 with lights and smoke signals; 2 with buoyant lines (L1)	A	≥60 m	NA	NA	NA
<u>8 x lifebuoys</u> : 2 with lights; 2 with lights and smoke signals; 2 with buoyant lines (L1)	A	≥45 <60 m	≥60 m	NA	NA
<u>6 x lifebuoys</u> : 1 with light; 2 with lights and smoke signals; 2 with buoyant lines (L1)	A	≥25 <45 m	≥45 <60 m	NA	NA
<u>4 x lifebuoys</u> : 2 with lights and smoke signals; 2 with buoyant lines (L1)	A	NA	≥25 <45 m	NA	NA
<u>8 x lifebuoys</u> : 1 with light; 1 with buoyant line (L1)	A	NA	NA	≥60 m (L2)	NA
<u>6 x lifebuoys</u> : 1 with light, 1 with buoyant line (L1)	A	NA	NA	≥45 <60 m (L2)	≥60 m (L2)
<u>4 x lifebuoys</u> : 1 with light, 1 with buoyant line (L1)	A	NA	NA	≥25 <45 m (L2)	≥45 <60 m (L2)
<u>2 x lifebuoys</u> : 1 with light, 1 with buoyant line (L1)	A	≥10 <25 m		≥10 <25 m (L2)	≥10 <45 m (L2)

(Continued)

Table 2 cont.

Lifebuoys (cont)	Annex	1B	1C	1D	1E
1x lifebuoy with light (L1)	A	NA		<10 m (L2)	

KEY:

(L1) – Lights and smoke signals shall comply with Annex A.

(L2) – Additional to buoyancy requirements (General).

Lifejackets	Annex	1B	1C	1D	1E
Adult SOLAS lifejacket with light (L1) for 100% complement, plus child size SOLAS lifejacket with light (L1) for the greater of: 10% of the total capacity of passengers, or the number of children of mass less than 32 kg.	A	YES	NA	NA	NA
Coastal with light (L1) for 100% complement	G	NA	YES	NA	NA
Coastal for 100% complement	G	NA	NA	YES	

KEY:

(L1) – Lights shall comply with Annex A.

Distress signals	Annex	1B	1C	1D	1E
Parachute distress rockets – [qty to be carried shown in ()]	A	YES (6)	YES (3)	YES (3)	NA
Red hand-held flares – [qty to be carried shown in ()]		YES (4)	YES (2)	YES (2)	YES (2)
Hand-held orange smoke signals – [qty to be carried shown in ()]		YES (2)	YES (1)	YES (1)	YES (1)

Line throwing appliance	Annex	1B	1C	1D	1E
4 x rockets and lines	A	≥45 m		NA	NA

On board communications and alarm systems	Annex	1B	1C	1D	1E
General emergency alarm system	A	≥25 m			
Public address system (C1)	A	YES			

KEY:

(C1) – A public address system is required where the vessel has no other demonstrated effective means to address passengers in time of emergency.

Emergency lighting (hand-held)	Annex	1B	1C	1D	1E
Battery-operated torch [qty to be carried shown in ()]		YES (2)	NA		
Battery-operated torch for each crew member		NA	YES		
Medical supplies	Annex	1B	1C	1D	1E
Medicines and medical stores	H	YES			

Key to Table 2:

1. For vessels of Class 1A—Refer to *Marine Order 25 (Equipment — life-saving) 2014*.
2. 'YES' means that the specific requirement applies to all vessels in that class.
3. 'NA' means not applicable.

Table 3 — Scales of safety equipment for Class 2 vessels

Liferafts and rescue boats	Annex	2B	2C	2D	2E
As required by sections 33 to 35 of <i>Marine Order 25 (Equipment — life-saving) 2014</i> (R1)	D / B	≥25 m		NA	NA
Inflatable Coastal liferaft for 100% complement	D	<25 m	<25 m ≥15 m	NA	NA
Inflatable Coastal liferaft for 100% complement (R2)	D	NA	<15 m	NA	NA

KEY:

(R1) – On vessels continuously engaged on voyages in operational areas with a monthly mean water temperature of 15°C or less, an anti-exposure suit of an appropriate size shall be provided for every person assigned to crew the rescue boat. For the requirements in Marine Order 25, a lifeboat must be a SOLAS life boat, a rescue boat must be a non-SOLAS rescue boat and a liferaft must be an inflatable coastal liferaft.

(R2) – Not required if vessel is fitted with level flotation in accordance with NSCV Part C Section 6B.

Buoyant appliances (general)	Annex	2B	2C	2D	2E
A dinghy plus sufficient buoyant appliances, lifebuoys (B4) or both for 100% complement	C / F / A	NA	NA	≥25 m (B1)	NA
Sufficient buoyant appliances, lifebuoys (B4) or both for 100% complement	F / A	NA	NA	<25 m ≥15 m (B1, B2, B5)	NA
Sufficient buoyant appliances, lifebuoys (B4), dinghies or combination for 100% complement	F / A / C	NA	NA	NA	≥15 m (B5)
Sufficient buoyant appliances, lifebuoys (B4), or both for 100% complement (B6)	F / A	NA	NA	NA	<15 m (B5)
Sufficient buoyant appliances, lifebuoys (B4), or both, for 100% complement or dinghy for 100% complement (B6)	F / A / C	NA	NA	<15 m (B1, B5)	NA

KEY:

(B1) – A reduction in buoyant appliance capacity may be allowed following assessment in accordance with Clause 2.21.

(B2) – A dinghy may be included for rescue of persons overboard.

(B4) – Each lifebuoy is assumed to provide support for two (2) persons.

(B5) – Vessels less than 25 m in measured length shall have suitable equipment on board to sustain and effectively recover persons overboard, e.g. heaving line with rescue quoit, ladder, rescue sling, scramble net.

(B6) – Not required if vessel is fitted with level flotation in accordance with NSCV Part C Section 6B.

Lifebuoys	Annex	2B	2C	2D	2E
<u>8 x lifebuoys</u> : 2 with lights; 2 with lights and smoke signals; 2 with buoyant lines (L1)	A	≥60 m		NA	NA
<u>6 x lifebuoys</u> : 1 with light; 2 with lights and smoke signals; 2 with buoyant lines (L1)	A	≥45 <60 m		NA	NA
<u>4 x lifebuoys</u> : 2 with lights and smoke signals; 2 with buoyant lines (L1)	A	≥25 <45 m		NA	NA
<u>2 x lifebuoys</u> : 1 with light; 1 with buoyant line (L1)	A	≥15 <25 m		≥15 m (L3)	
<u>1 x lifebuoy</u> with light (L1)	A	<15 m	<15 m (L4)	<15 m (L3)	

KEY

(L1) – Lights and smoke signals shall comply with Annex A.

(L3) – Included in Buoyancy Requirements (General).

(L4) – Not required if vessel is less than 10 m and carries 1 person only; or vessel is less than 6 m and fitted with level flotation in accordance with Part C Section 6.

(Continued)

Table 3 cont.

Lifejackets	Annex	2B	2C	2D	2E
Adult SOLAS lifejacket with light (L1) for 100% complement, plus child size SOLAS lifejacket with light (L1) for the greater of: 10% of the total capacity of passengers, or the number of children of mass less than 32 kg.	A	YES	NA	NA	NA
Coastal with light for 100% complement (L1)	G	NA	YES	NA	NA
Coastal for 100% complement	G	NA	NA	YES	

KEY:

(L1) – Lights shall comply with Annex A.

Distress signals	Annex	2B	2C	2D	2E
Parachute distress rockets – [qty to be carried shown in ()]	A	YES (6)	YES (3)	YES (3)	NA
Red hand-held flares – [qty to be carried shown in ()]		YES (4)	YES (2)	YES (2)	YES (2)
Hand-held orange smoke signals – [qty to be carried shown in ()]		YES (2)	YES (1)	YES (1)	YES (1)

On board communications and alarm systems	Annex	2B	2C	2D	2E
General emergency alarm system	A	≥25 m			
Emergency lighting (hand-held)	Annex	2B	2C	2D	2E
Battery-operated torch [qty to be carried shown in ()]		YES (2)	NA		
Battery-operated torch for each crew member		NA	YES		
Medical supplies	Annex	2B	2C	2D	2E
Medicines and medical stores	H	YES			

NOTES:

1. For vessels of Class 2A—Refer to *Marine Order 25 (Equipment — life-saving) 2014*.
2. 'YES' means that the specific requirement applies to all vessels in that class.
3. 'NA' means not applicable.

Table 4 — Scales of safety equipment for Class 3 vessels

Liferafts and rescue boats	Annex	3B	3C	3D	3E
As required by sections 33 to 35 of <i>Marine Order 25 (Equipment — life-saving) 2014</i> (R1)	D / B	≥25 m		NA	NA
Inflatable Coastal liferaft for 100% complement	D	<25 m	<25 m ≥15 m	NA	NA
Inflatable Coastal liferaft for 100% complement (R2)	D	NA	<15 m	NA	NA

KEY:

(R1) – On vessels continuously engaged on voyages in operational areas with a monthly mean water temperature of 15° C or less, an anti-exposure suit of an appropriate size shall be provided for every person assigned to crew the rescue boat. For the requirements in Marine Order 25, a lifeboat must be a SOLAS life boat, a rescue boat must be a non-SOLAS rescue boat and a liferaft must be an inflatable coastal liferaft.

(R2) - Not required if vessel is fitted with level flotation in accordance with NSCV Part C Section 6B.

Buoyant appliances (general)	Annex	3B	3C	3D	3E
A dinghy plus sufficient buoyant appliances, lifebuoys (B5) or both for 100% complement	C / F / A	NA	NA	≥25 m (B1)	NA
Sufficient buoyant appliances, lifebuoys (B4) or both for 100% complement	F / A	NA	NA	<25 m ≥15 m (B2, B5)	NA
Sufficient buoyant appliances, lifebuoys (B4), dinghies or combination for 100% complement	F / A / C	NA	NA	NA	≥15 m (B5)
Sufficient buoyant appliances, lifebuoys (B4) or both for 100% complement, (B6)	F / A	NA	NA	NA	<15 m (B5)
Sufficient buoyant appliances, lifebuoys (B4), or both for 100% complement, or a dinghy for 100% complement, (B6)	F / A / C	NA	NA	<15 m (B5)	NA

KEY:

(B1) – A reduction in buoyant appliance capacity may be allowed following assessment in accordance with Clause 2.21.

(B2) – A dinghy may be included in the combination for rescue of persons overboard.

(B4) – Each lifebuoy is assumed to provide support for two (2) persons.

(B5) – Vessels less than 25 m in measured length shall have suitable equipment on board to sustain and effectively recover persons overboard, e.g. heaving line with rescue quoit, ladder, rescue sling, scramble net.

(B6) - Not required if vessel is fitted with level flotation in accordance with NSCV Part C Section 6B.

Lifebuoys	Annex	3B	3C	3D	3E
<u>8 x lifebuoys</u> : 2 with lights; 2 with lights and smoke signals; 2 with buoyant lines (L1)	A	≥60 m		NA	NA
<u>6 x lifebuoys</u> : 1 with light; 2 with lights and smoke signals; 2 with buoyant lines (L1)	A	≥45 <60 m		NA	NA
<u>4 x lifebuoys</u> : 2 with lights and smoke signals; 2 with buoyant lines (L1)	A	≥25 <45 m		NA	NA
<u>2 x lifebuoys</u> : -1 with light, 1 with buoyant line (L1)	A	≥15 <25 m		≥15 (L3)	
<u>1 x lifebuoy</u> with light (L1)	A	<15 m	<15 m (L4)	<15 m (L3)	

KEY:

(L1) – Lights and smoke signals shall comply with Annex A.

(L3) – Included in Buoyancy Requirements (General)

(L4) – Not required if vessel is less than 10 m. and carries 1 person only, or vessel is less than 6 m and fitted with level flotation in accordance with NSCV Part C Section 6B.

(Continued)

Table 4 cont.

Lifejackets	Annex	3B	3C	3D	3E
Adult SOLAS lifejacket with light (L1) for 100% complement, plus child size SOLAS lifejacket with light (L1) for the greater of: 10% of the total capacity of passengers, or the number of children of mass less than 32 kg.	A	YES	NA	NA	NA
Coastal with light for 100% complement (L1)	G	NA	YES	NA	NA
Coastal for 100% complement	G	NA	NA	YES	

KEY

(L1) – Lights shall comply with Annex A.

Distress signals	Annex	3B	3C	3D	3E
Parachute distress rockets - [quantity to be carried shown in ()]	A	YES (6)	YES (3)	YES (3)	NA
Red hand-held flares - [quantity to be carried shown in ()]		YES (4)	YES (2)	YES (2)	YES (2)
Hand-held orange smoke signals - [quantity to be carried shown in ()]		YES (2)	YES (1)	YES (1)	YES (1)

On board communications and alarm systems	Annex	3B	3C	3D	3E
General emergency alarm system	A	≥25 m		NA	NA
Emergency lighting (hand-held)	Annex	3B	3C	3D	3E
Battery-operated torch [quantity to be carried shown in ()]		YES (2)	NA		
Battery-operated torch for each crew member		NA	YES		
Medical supplies	Annex	3B	3C	3D	3E
Medicines and medical stores	H	YES			

NOTES:

1. For vessels of Class 3A—Refer to *Marine Order 25 (Equipment — life-saving) 2014*.
2. 'YES' means that the specific requirement applies to all vessels in that class.
3. 'NA' means not applicable.

CHAPTER 6 SERVICING OF SAFETY EQUIPMENT

6.1 SCOPE

This Chapter specifies requirements for the servicing of safety equipment.

6.2 OBJECTIVE

The objective of this Chapter is to specify minimum standards for the servicing of safety equipment so that the effectiveness of the safety systems can be maintained.

NOTES:

1. The servicing of safety equipment effectively assures that compliance of the equipment with the National Standard is maintained. Servicing also provides the opportunity for the delegated periodic survey inspection of the equipment on behalf of the Authority.
2. Procurement of safety equipment requiring servicing should take into account the long-term availability of geographically practicable servicing stations approved by the manufacturer of the safety equipment.

6.3 ASSESSMENT METHODS

Assessment methods for servicing of safety equipment shall be verified in a manner appropriate to the risks that would arise should the safety system fail to perform at time of need.

NOTE: Assessment methods applicable to servicing of safety equipment tend to be rigorous to promote reliability of performance. Special diligence is needed to avoid the possibility of equipment failing to perform at time of need. In addition to the need for rigorous assessment, options for equivalent solutions may be limited by enabling legislation.

6.4 INFLATABLE COASTAL AND OPEN REVERSIBLE LIFERAFTS

Inflatable Coastal and open reversible liferafts shall be serviced at intervals of 12 months, or such longer intervals as recommended by the manufacturer and approved at the time the product is assessed and verified in accordance with Clause 3.3.2.

Servicing shall be carried out by a person or organisation that—

- a) is approved and accredited to do so by the manufacturer of the liferaft being serviced;
- b) possesses the current servicing manuals (including amendments) as provided by the liferaft manufacturer, and all updates to such manuals and other safety bulletins within one month of their publication;
- c) has access to genuine spare parts; materials and tools for each type and make of liferaft serviced;
- d) undertakes all necessary training as determined by the manufacturer to maintain expertise; and
- e) maintains a quality management system.

NOTE: A comprehensive service history of the liferaft detailed in a logbook would satisfy the quality management system requirement above.

6.5 MARINE EVACUATION SYSTEMS

Every marine evacuation system (MES) shall be serviced—

- a) at intervals of 12 months, or such longer intervals as recommended by the manufacturer and approved at the time the product is assessed and verified in accordance with Clause 3.3.2; and
- b) at a servicing station approved and accredited to do so by the manufacturer of the marine evacuation system.

6.6 INFLATABLE LIFEJACKETS

Every inflatable lifejacket shall be serviced—

- a) at intervals of 12 months, or such longer intervals as recommended by the manufacturer and approved at the time the product is assessed and verified in accordance with Clause 3.3.2; and
- b) at a servicing station approved and accredited to do so by the manufacturer of the inflatable lifejacket.

6.7 INFLATABLE NON-SOLAS RESCUE BOATS

All repairs and maintenance of inflatable rescue boats shall be carried out in accordance with the manufacturer's instructions. While emergency repairs may be carried out on board the vessel, permanent repairs shall be effected at a servicing station approved and accredited to do so by the manufacturer of the inflatable rescue boats.

6.8 HYDROSTATIC RELEASE UNITS

A hydrostatic release unit shall be inspected at intervals of 12 months or such longer intervals as recommended by the manufacturer and approved at the time the product is assessed and verified in accordance with Clause 3.3.2.

The inspection shall be conducted in situ to ensure that the unit has not activated and that attachments remain secure.

A hydrostatic release unit shall be replaced at the end of its specified life span in accordance with the manufacturer's instructions.

6.9 LAUNCHING APPLIANCES

Launching appliances shall be—

- a) serviced at recommended intervals in accordance with the manufacturer's instructions;
- b) subjected to a thorough examination at intervals not exceeding 5 years; and
- c) upon completion of the examinations in Clause 6.9 b) be subject to a dynamic test of the winch brake with a proof load of not less than 1.1 times the maximum working load limit at the maximum lowering speed.

6.10 EPIRBs

EPIRBs contained in inflatable liferafts shall be inspected and tested whenever the liferaft is serviced. The EPIRB shall also be serviced if required.

6.11 PYROTECHNIC AND SMOKE SIGNALS – PERIOD OF VALIDITY

Pyrotechnic and smoke signals shall be valid for a minimum of 3 years from the date of manufacture, or such longer intervals as recommended by the manufacturer and approved at the time the product is assessed and verified in accordance with Clause 3.3.2.

ANNEX A REQUIREMENTS FOR SOLAS EQUIPMENT

A1 SCOPE

This Annex A provides requirements for the construction, production and performance of SOLAS equipment. It forms a normative (mandatory) part of this document.

This Annex is referenced in Clause 3.3.1 and Table 2, Table 3, and Table 4 of this Subsection.

A2 GENERAL

The safety equipment listed in Table A.1 shall comply with the provisions of the relevant Marine Order for SOLAS vessels as specified in Table A.1.

For quality control, examination and general requirements, such safety equipment shall also comply with control provisions of *Marine Order 25 (Equipment — life-saving) 2014* for SOLAS vessels or for class A vessels over 500 gross tonnage.

Table A.1—Construction, production and performance requirements for SOLAS equipment

Item	Marine Order	Item	Marine Order
Buoyant smoke signal	25	Public address system	25
Embarkation ladder	25	Retro-reflective tape (use and fitting)	25
EPIRB, 406 MHz	25	Rocket parachute flare	25
Evacuation system	25	SOLAS first aid kit	25
Fast rescue boat	25	SOLAS launching appliance	25
General emergency alarm system		SOLAS lifeboat	25
Hand flare	25	SOLAS lifejacket	25
Anti-exposure suit	25	SOLAS lifejacket light	25
Lifebuoy	25	SOLAS liferaft	25
Lifebuoy buoyant line	25	SOLAS lifeboat/rescue boat recovery arrangement	25
Lifebuoy light	25	SOLAS rescue boat	25
Lifebuoy smoke signal	25	Thermal protective aid	25
Line-throwing appliance	25	Two-way VHF radiotelephone apparatus	27
		Radar transponder	27

ANNEX B REQUIREMENTS FOR NON-SOLAS RESCUE BOATS

B1 SCOPE

This Annex B provides requirements for the design, construction, and marking of non-SOLAS rescue boats. It forms a normative (mandatory) part of this document.

This Annex is referenced in Clauses 3.3.1 and 4.4.1, and Table 2, Table 3 and Table 4 of this Subsection.

B2 DESIGN AND CONSTRUCTION

B2.1 General

A non-SOLAS rescue boat shall comply with the following requirements:

- a) The minimum length of the boat shall be 3.8 m.
- b) The boat design and construction criterion specified in column 1 of Table B.1 shall comply with the standard specified in column 2 of Table B.1.

Table B.1 — Design and construction standards for non-SOLAS rescue boats

Criterion description	Standard
Construction	Part C Section 3; or AS 2677
Intact stability	Part C Section 6A
Reserve buoyancy and swamping including the fitting of buoyancy materials	Part C Section 6B

B2.2 Colour

A non-SOLAS rescue boat shall be of a highly visible colour.

B3 FITTINGS

B3.1 Grab-lines

Grab-lines shall be secured to the side of the rescue boat to support the upper torso of a person out of the water when holding onto them and to facilitate recovery of persons.

Grab-lines shall not be secured more than 150 mm or less than 100 mm below the gunwale. The securing points shall be spaced at not more than 460 mm or less than 300 mm centres and interlaced to prevent movement. The depth of the loop when at right angles to the vessel shall be not more than 200 mm or less than 150 mm.

B3.2 Towing

Arrangements for towing shall be permanently fitted to the rescue boat and be sufficiently strong to marshal and tow liferafts as required in Clause B4 a).

B3.3 Lifting system

A non-SOLAS rescue boat shall comply with the lifting system requirements of AS 1799.1. The lifting system shall be capable of lifting the rescue boat when loaded with two (2) persons each assumed to be of 80 kg weight, and its full outfit of equipment.

NOTE: This Clause does not imply that rescue boats are required to be launched and retrieved with persons on board.

B3.4 Painter

A non-SOLAS rescue boat shall be fitted with a painter that shall be of sufficient length to allow deployment of the rescue boat from its maximum possible height and have a breaking strength of 10 kN.

B4 EQUIPMENT

A non-SOLAS rescue boat shall be equipped with the following:

- a) A motor(s) of sufficient power to provide mobility and manoeuvrability in a seaway to enable persons to be retrieved from the water and to marshal / tow liferafts. The maximum power capacity shall be determined in accordance with the requirements of AS 1799.1.
- b) Lifejackets, additional to those required to be carried on the parent vessel, shall be provided for every person assigned to crew the rescue boat. Buoyant anti-exposure suits, where provided, shall be deemed to satisfy this requirement.
- c) A waterproof, battery-operated torch.
- d) A bailer of robust construction fitted with a lanyard, or a bilge pump.
- e) Oars or paddles.
- f) A heaving line with rescue quoit.

For inflatable rescue boats the following equipment shall also be supplied:

- i) A bellows or pump complete with hose and adapter to suit inflation valves and which shall be capable of inflating the rescue boat to normal working pressure.
- ii) Emergency repair kit, complete with suitable patches, adhesive and instructions.

B5 MARKING OF RESCUE BOATS**B5.1 Retro-reflective tapes**

Retro-reflective tapes shall comply and be fitted in accordance with the requirements for rescue boats in *Marine Order 25 (Equipment — life-saving) 2014* for class A vessels over 500 gross tonnage.

B5.2 Persons capacity

The persons capacity of a non-SOLAS rescue boat shall be determined in accord with AS 1799.1 using 80 kg as the average weight of a person and shall be legibly and permanently marked upon it in contrasting colours in figures not less than 75 mm in height.

ANNEX C REQUIREMENTS FOR DINGHIES

C1 SCOPE

This Annex C provides requirements for the design, construction, and marking of dinghies. It forms a normative (mandatory) part of this document.

This Annex is referenced in Clauses 3.3.1 and 4.6.1 and Table 2, Table 3 and Table 4 of this Subsection.

C2 DESIGN AND CONSTRUCTION

C2.1 General

A dinghy shall comply with the following requirements:

- a) The minimum length of the dinghy shall be 2.4 m.
- b) The dinghy design and construction criterion specified in column 1 of Table C.1 shall comply with the standard specified in column 2 of Table C.1.

Table C.1 — Design and construction standards for dinghies

Criterion description	Standard
Construction	Part C Section 3
Intact stability	Part C Section 6A
Reserve buoyancy and swamping including the fitting of buoyancy materials	Part C Section 6B

C2.2 Colour

A dinghy shall be of a highly visible colour.

C3 FITTINGS

C3.1 Grab-lines

The dinghy shall be fitted with grab-lines, which are effective with the dinghy upright or upturned.

Grab-lines, as shown in Figure C.1, shall not be secured more than 150 mm or less than 100 mm below the gunwale. The securing points shall be spaced at not more than 460 mm or less than 300 mm centres and interlaced to prevent movement. The depth of the loop when at right angles to the vessel shall be not more than 200 mm or less than 150 mm.

C4 EQUIPMENT

A dinghy shall be equipped with the following:

- a) Two (2) oars and rowlocks, or paddles.
- b) One (1) painter attached to bow.
- c) One (1) bucket or bailer, attached by lanyard.
- d) One (1) bung permanently attached by lanyard.

C5 MARKING

C5.1 Retro-reflective tapes

Retro-reflective tapes shall comply and be fitted in accordance with the requirements of *Marine Order 25 (Equipment — life-saving) 2014* for class A vessels over 500 gross tonnage and Figure C.1.

C5.2 Persons capacity

The persons capacity of a dinghy shall be determined in accord with AS 1799.1 using 80 kg as the average weight of a person and shall be legibly and permanently marked upon the dinghy's transom in contrasting colours in figures not less than 75 mm in height.

Figure C.1—Dinghy marking and grab-lines

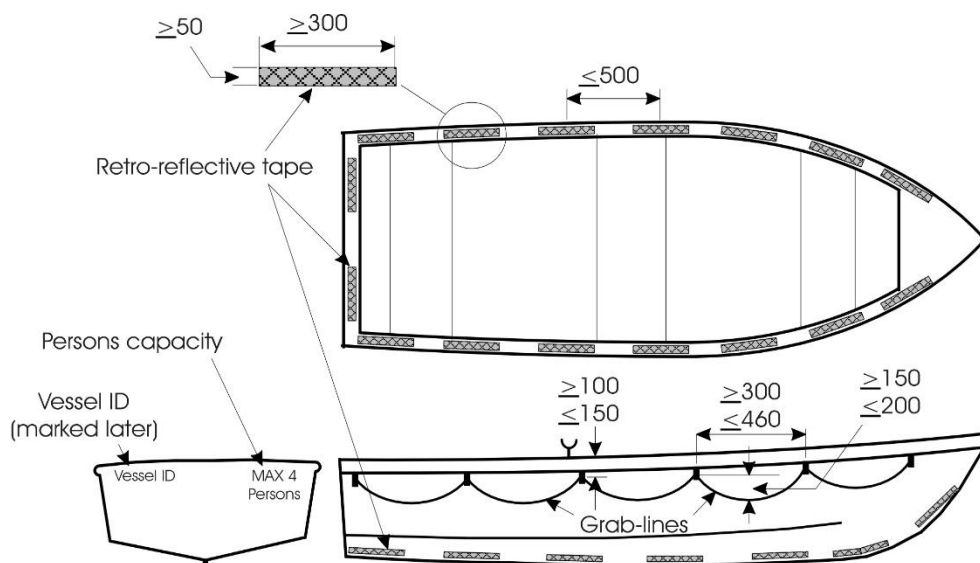

ANNEX D REQUIREMENTS FOR INFLATABLE COASTAL LIFERAFTS

D1 SCOPE

This Annex D provides requirements for the design, construction, fittings, equipment, rations, stowage, launching, performance testing and marking of inflatable coastal liferafts. It forms a normative (mandatory) part of this document.

This Annex is referenced in Clause 3.3.1 and Table 1, Table 2, Table 3 and Table 4 of this Subsection.

D2 DESIGN AND CONSTRUCTION

An inflatable coastal liferaft shall comply with either:

- a) for liferafts that carry up to 12 persons - the requirements for a Group A liferaft specified in ISO 9650-1 and this Annex; or
- b) for liferafts that carry more than 12 persons – the requirements of the *International Life-Saving Appliance Code 2016* (LSA Code) Chapter IV, section 4.2 and the requirements specified in this Annex other than D5.2.

Where there is any conflict in requirements between the ISO 9650-1 specifications or the LSA Code, and this Annex, the requirements in this Annex shall apply.

D3 EQUIPMENT AND RATIONS

An inflatable Coastal liferaft shall be fitted with the following equipment and rations:

- a) for a liferaft that carries up to 12 persons and complies with ISO 9650-1 – all of the following:
 - i) the fittings specified in ISO 9650-1; and
 - ii) the equipment and rations specified for one Equipment Pack 1 >24 hrs in ISO 9650-1; and
 - iii) one class 3 EPIRB, 406MHz; or
- b) for a liferaft that carries more than 12 persons and complies with the LSA Code – the equipment and rations specified in the LSA Code paragraph 4.1.5.1 (SOLAS PACK A) as modified by *Marine Order 25 (Equipment – lifesaving) 2014*, Schedule 1 Section 10 (Liferaft equipment).

D4 STOWAGE AND LAUNCHING

D4.1 Stowage

Coastal liferafts shall be stowed in accordance with Chapter 4 of this Subsection.

D4.2 Mass

Unless designed to be launched by a launching appliance or marine evacuation system, or is stowed such that one person can launch it in adverse conditions, the liferaft shall be capable of being launched by 2 persons.

D4.3 Hydrostatic release unit

The liferaft painter shall provide a connection between the parent vessel and the liferaft at the vessel end of the painter so arranged as to ensure that the liferaft is not dragged under by the sinking vessel.

A hydrostatic release unit shall be used in the float-free arrangement. The hydrostatic release unit shall:

- a) Be constructed of compatible materials so as to prevent malfunction of the unit. Galvanizing or other forms of metallic coating on parts of hydrostatic release unit is not acceptable.
- b) Automatically release the liferaft at a depth of not more than 4 m.
- c) Have drains to prevent the accumulation of water in the hydrostatic release chamber when the unit is in its normal position.
- d) Be so constructed as to prevent release when seas wash over the unit.
- e) Be permanently and legibly marked on its exterior with its type and serial number.
- f) Be permanently and legibly marked on the unit or identification plate securely attached to the unit stating the date of manufacture, type and serial number and whether or not the unit is suitable for use with a liferaft with a capacity of more than 25 persons.
- g) Be such that each part connected to the painter system has a strength of not less than that required for the painter.
- h) Indicate in a way that cannot be removed the date by which it is to be replaced.

D4.4 Launching

A liferaft designed for launching inflated with a launching appliance shall be of sufficient strength to permit it to be safely lowered into the water when loaded with its full complement of persons and equipment.

D4.5 Instructions for the parent vessel

The instructions supplied with a liferaft shall include how to stow the liferaft the correct side up, in an appropriate stowage and secure the painter.

D5 MARKING

D5.1 Retro-reflective material

Retro-reflective material shall comply and be fitted in accordance with the inflatable liferaft requirements of *Marine Order 25 (Equipment — life-saving) 2014* for class A vessels over 500 gross tonnage.

D5.2 Product information

In addition to the requirements of ISO 9650-1, the liferaft and its container or valise, and also an accompanying certificate, which shall be kept on board the parent vessel, shall include the words: '*Coastal Liferaft*'.

D6 SERVICING

Coastal liferafts shall be serviced in accordance with Chapter 6 of this Subsection.

ANNEX E REQUIREMENTS FOR OPEN REVERSIBLE LIFERAFTS

E1 SCOPE

This Annex E provides requirements for the design, construction, fittings, equipment, rations, stowage, launching, performance testing and marking of open reversible liferafts. It forms a normative (mandatory) part of this document.

This Annex is referenced in Clauses 3.3.1 and 4.5.1, and Table 1 of this Subsection.

E2 DESIGN AND CONSTRUCTION

An open reversible liferaft shall comply with the requirements specified in—

- a) either:
 - i) Annex 11 of International Code of Safety for High-Speed Craft; or
 - ii) for a vessel operating in operational areas D or E – both:
 - a. Annex 11 of the International Code of Safety for High-Speed Craft, other than clause 2.10; and
 - b. the number of persons which the open reversible liferaft is permitted to carry is calculated as the lesser of:
 - i. the greatest whole number obtained by dividing the volume, measured in cubic metres, of the main buoyancy tubes (which for this purpose shall not include the thwarts, if fitted) when inflated by 0.064; or
 - ii. the greatest whole number obtained by dividing the inner horizontal cross-sectional area of the open reversible liferaft measured in square metres (which for this purpose may include the thwart or thwarts, if fitted) measured to the innermost edge of the buoyancy tubes by 0.248; or
 - iii. the number of persons having an average mass of 80 kg, all wearing lifejackets, that can be seated inboard of the buoyancy tubes without interfering with the operation of any of the liferaft's equipment; and
- b) this Annex.

Where there is any conflict in requirements between the HSC Code specifications and this Annex, the requirements in this Annex shall apply.

E3 FITTINGS

E3.1 Painter system

The breaking strength of the painter system including its means of attachment to the open reversible liferaft shall be—

- a) 7.5 kN for open reversible liferafts accommodating up to 8 persons;
- b) 10.0 kN for open reversible liferafts accommodating 9 to 30 persons; and
- c) 15.0 kN for open reversible liferafts accommodating more than 30 persons.

E3.2 Hydrostatic release unit

The liferaft painter system shall provide a connection between the parent vessel and the liferaft and shall be so arranged as to ensure that the sinking vessel does not drag the liferaft under when it is released and inflated.

A hydrostatic release unit shall be used in the float-free arrangement and shall satisfy the following conditions:

- a) Be constructed of compatible materials so as to prevent malfunction of the unit. Galvanizing or other forms of metallic coating on parts of hydrostatic release unit is not acceptable.
- b) Automatically release the liferaft at a depth of not more than 4 m.
- c) Have drains to prevent the accumulation of water in the hydrostatic release chamber when the unit is in its normal position.
- d) Be so constructed as to prevent release when seas wash over the unit.
- e) Be permanently and legibly marked on its exterior with its type and serial number.
- f) Be permanently and legibly marked on the unit or identification plate securely attached to the unit stating the date of manufacture, type and serial number and whether or not the unit is suitable for use with a liferaft with a capacity of more than 25 persons.
- g) Be such that each part connected to the painter system has a strength of not less than that required for the painter.
- h) Indicate in a way that cannot be removed, the date by which it is to be replaced.

ANNEX F REQUIREMENTS FOR BUOYANT APPLIANCES

F1 SCOPE

This Annex F provides requirements for the design, construction, and launching of buoyant appliances. It forms a normative (mandatory) part of this document.

This Annex is referenced in Clauses 3.3.1 and 4.7.1 and Table 1, Table 2, Table 3 and Table 4 of this Subsection.

F2 DESIGN AND CONSTRUCTION

F2.1 General

A buoyant appliance shall be designed and constructed to retain its shape and strength under all conditions of service and be equally stable whichever way up it is deployed.

F2.2 Buoyant material

The buoyant material in a buoyant appliance shall comply with the relevant requirements of IMO Resolution MSC.81(70).

F2.3 Outer covering and fittings

The buoyant material shall be sealed in a waterproof fire retardant outer covering of a highly visible colour, which is designed to protect the buoyant material from mechanical damage. The outer covering of the appliance and all exposed fittings shall be rot-proof, corrosion resistant, resistant to fungal attack, and resistant to degradation from exposure to—

- a) petroleum products;
- b) weather and sea water; and
- c) ultraviolet light.

F2.4 Resistance to impact

A buoyant appliance shall be designed and manufactured to withstand, without incurring any damage or loss in performance, being dropped into the water from a height of 6 m or from a height at which the appliance will be stowed relative to the vessel's water line in the vessel's lightest condition, whichever is the greater.

F2.5 Grab-line

The buoyant appliance shall incorporate a rot-proof buoyant grab-line in the form of a continuous length of rope looped around the appliance, and shall comply with Figure F.1 and the following:

- a) The diameter of the rope shall not be less than 10 mm.
- b) The distance between the points of attachment of the loops to the appliance shall not be greater than 450 mm or less than 300 mm between centres.
- c) Each loop of buoyant line shall have a depth of not less than 150 mm and not more than 200 mm.
- d) Both the loops and their fastenings to the appliance shall be of sufficient strength to enable the appliance to be lifted by a single loop without causing a decrease in the sag of any other loop.
- e) The end of each loop shall be knotted, seized or otherwise secured at the ends of each loop so that breakage of the rope at one loop will not render all other loops unusable.

F2.6 Painter

A buoyant appliance shall be fitted with a painter that shall be of sufficient length to allow deployment of the buoyant appliance from its maximum possible height and have a breaking strength of 10 kN.

F2.6.1 Painter attachment point

A buoyant appliance shall incorporate a strong point to which the painter may be attached of sufficient strength to prevent the appliance from drifting away from the vessel after deployment.

F2.7 Capacity

The number of persons that the appliance is able to support shall be the lesser of the total number of grab-line loops around the appliance, or the value obtained from the following formula:

$$N = 70 \left(V - \frac{W}{1000} \right)$$

where

N = number of persons, rounded down to the nearest whole number

V = volume of appliance, in cubic metres

W = mass of appliance, in kilograms

F3 LAUNCHING

Unless a launching device is provided, the buoyant appliance shall be capable of being launched by 2 persons. Where the appliance exceeds 136 kg, handles or rings shall be fitted to facilitate launching by hand. Such handles or rings shall be fitted in addition to the grab-lines specified in Clause F2.5.

F4 MARKING**F4.1 Persons capacity**

The persons capacity of buoyant appliances shall be legibly and permanently marked on both of the largest faces of the buoyant appliances in figures not less than 75 mm in height.

F4.2 Retro-reflective tapes

Retro-reflective tapes shall comply with the requirements of *Marine Order 25 (Equipment — life-saving) 2014* for class A vessels over 500 gross tonnage and Figure F.1.

Unless otherwise specified, each strip of standard tape shall be not less than 300 mm long and not less than 50 mm wide. Alignment of tapes shall be such that the distance between the centre of the tape and the centre of the next tape in line shall not exceed 500 mm.

F4.3 Location of tapes

The top and bottom of a buoyant appliance shall be fitted with strips of retro-reflective tape spaced around the perimeter of the appliance so that the distance between the centres of consecutive strips is not greater than 500 mm.

Figure F.1—Buoyant appliance marking and grab-lines

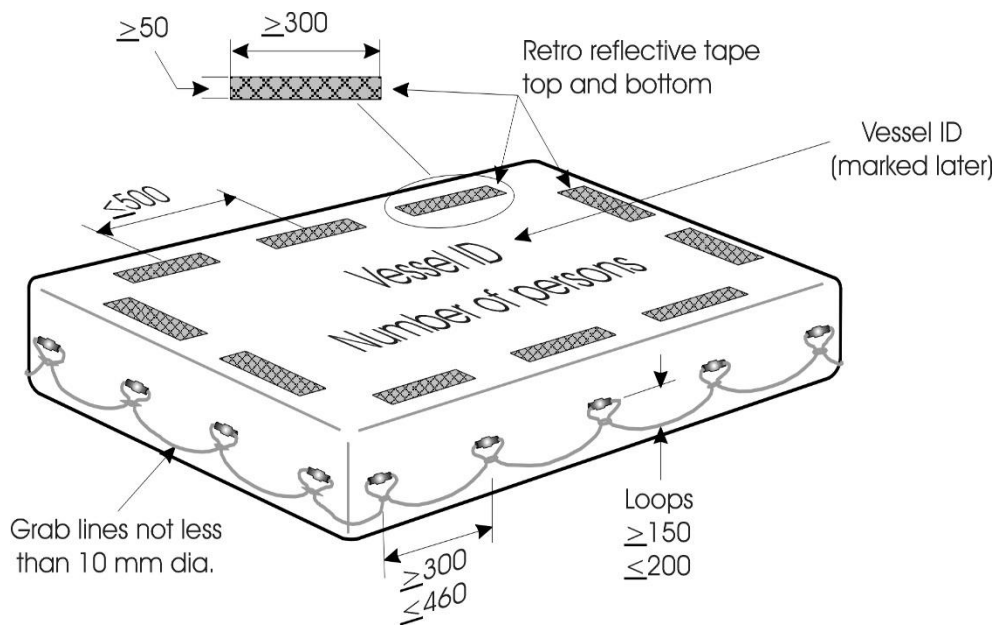

ANNEX G REQUIREMENTS FOR COASTAL LIFEJACKETS

G1 SCOPE

This Annex G provides requirements for the design, construction, marking, testing and performance of Coastal lifejackets. It forms a normative (mandatory) part of this document.

This Annex is referenced in Clause 3.3.1 and Table 1, Table 2, Table 3 and Table 4 of this Subsection.

G2 DESIGN AND CONSTRUCTION

A Coastal lifejacket shall comply with the requirements specified in—

- a) AS 4758.1; or
- b) ISO 12402-3 (Level 150); or
- c) BS EN 396; and
- d) this Annex.

Where AS 4758.1 is used to demonstrate compliance, the requirements for Level 150 shall apply.

Where there is any conflict in requirements between the AS 4758.1 or ISO 12402-3 or BS EN 396 specifications and this Annex, the requirements in this Annex shall apply.

G2.1 Inflation system

Inflatable lifejackets that rely solely on oral inflation for buoyancy are not acceptable under this standard.

G2.2 Lifejacket lights

Coastal lifejacket lights shall comply with the requirements of *Marine Order 25 (Equipment — life-saving) 2014* for class A vessels over 500 gross tonnage.

ANNEX H REQUIREMENTS FOR MEDICAL SUPPLIES

H1 SCOPE

This Annex H provides requirements for the first aid, medical supplies and associated equipment on board vessels and includes requirements relating to inventories; labelling; packaging and expiry date control of medicines and medical equipment; and the construction, location and marking of medical cabinets and first aid kits. It forms a normative (mandatory) part of this document.

This Annex is referenced in Table 2, Table 3, and Table 4.

H2 OBJECTIVE

The objective of this Annex H is to specify the medical supplies necessary to treat minor medical conditions or injuries, or to temporarily stabilise a patient until transfer to medical assistance can be arranged.

H3 GENERAL

H3.1 Medical supplies advice

Owners and operators should obtain medical advice from their consultant medical practitioners or pharmacists in specifying medical supplies for their vessels, especially should they wish to add to the mandatory listings.

NOTES:

1. The supplies and quantities specified in this Annex are based on experience of the range of medical and surgical emergencies that can arise on board a vessel. However, they may need to be expanded in accordance with the particular risks inherent to the voyage, the length of the voyage, access to medical facilities, the cargoes carried, and the numbers of persons on board.
2. In addition to this Annex H, other requirements for first aid, medical supplies and associated equipment, medical incident reporting procedures, storage, disposal, labelling and first aid training may be mandatory under other Commonwealth and state / territory legislation including OH&S legislation. In addition Codes of Practice and Australian Standards may exist that relate to medical supplies.

H3.2 Equipment and supplies to be carried

All vessels shall carry the medical equipment and supplies specified in Table H.3, Table H.4, and/or Table H.5, as applicable to the vessel, dependant on its class and operating area. Table H.2 identifies the scales applicable to vessel class and operational area.

The scales of medical equipment and supplies specified in Table H.3 to Table H.5 are those required for single incident events involving 1 or 2 persons, and are based on the assumption that medical assistance will be achieved within the time periods specified in Table H.1.

NOTE: If unsure of the nature or seriousness of an illness or injury, radio medical advice should be sought and, if necessary, medical evacuation by helicopter should be initiated.

Table H.1 – Medical assistance times

Time period in which medical assistance can be obtained	Scale
2 hours	Scale G
6 hours	Scale F
12 hours	Scales E and D

H4 CARRIAGE OF DANGEROUS GOODS

All vessels carrying as cargo, or in shipboard use, any quantity of a hazardous or dangerous chemical or goods, as defined under the International Maritime Dangerous Goods (IMDG) Code, shall have available on board the appropriate additional first aid, medicinal antidotes and other additional treatments as specified by the manufacturer, supplier or other authorised body or publication, including the material safety data sheets relating to the hazardous chemical or goods.

H5 EXPIRY DATES

Medical supplies carried in accordance with this Subsection shall not exceed the expiry date specified by the manufacturer or supplier of the product.

All medicines have an expiry date. Expired or surplus medications should be returned to a pharmacist for appropriate disposal.

Unused controlled drugs shall not be disposed of other than by transferring them to the control of a registered pharmacist.

H6 REPLACEMENT OF STOCKS

Antibiotics shall always be supplied in original packages or patient courses; however, other products such as analgesics and creams shall be considered adequate if an opened package contains at least 50 per cent of the original quantity, and the remaining product is uncontaminated and unaffected by any expiry date as a result of any seal being broken.

NOTE: This provision is to avoid unwarranted additional supply after a few tablets or capsules are consumed.

H7 LABELLING AND PACKAGING

Medication should be provided in original, sealed blister or foil packs where possible.

All products shall carry instructions and directions for use in English and clearly state the adult dose where applicable to enable safe and effective use of the medication for the intended purpose(s).

Children's doses, with weight or age criteria, can be shown if space permits on the label. It should be understood, however, that the medical inventories for vessels are designed for adult passengers and crew. If a child requires treatment, then radio medical advice should be sought.

All medicines and, where necessary, first aid stocks should carry cautionary and advisory labelling, as provided for in the Australian Pharmaceutical Formulary (APF) to alert Masters or patients as to issues of sedation or interaction with food or alcohol, etc. This ancillary labelling may be printed by the manufacturer on the packaging, included on a dispensing label, or by cautionary and advisory stickers.

The following details should be supplied on the label:

- a) The expiry date and batch number.
- b) The generic or drug name (the brand name is optional unless repackaged).
- c) The strength or quantity as applicable.
- d) The instruction(s) for use and adult dose or directions for safe and effective administration.
- e) The supplying pharmacist's name, address and telephone number on schedule 4 and higher medicines and substances.

NOTES: Pharmacists are cautioned to avoid placing labels over the manufacturer's expiry date or batch numbers and to provide original unopened packs, if possible. Where the choice of brands provides for blister or foil packaging, or other sealed packs, these are preferred in the harsh sea-going environment.

H8 MEDICAL LOG BOOK

All vessels shall carry and record the use of all medicines, first aid and medical incidents in a Medical Log Book (to include the time, patient, condition and treatment) and record the stock movements for Controlled (#) Drugs in a Controlled Drugs Register. This includes the supply, use, disposal, loss or theft of such controlled (#) drugs.

H9 FIRST AID KIT

H9.1 Application

A vessel to which Scale D or E applies must also carry at least 1 first aid kit in accordance with Scale F.

A vessel to which Scale G applies may carry a first aid kit in accordance with Scale F instead of a first aid kit in accordance with Scale G.

H9.2 Location

The first aid kit shall be located adjacent to the Master's accommodation, or in the wheelhouse. In small partly open vessels, the first aid kit shall be stowed so as to protect it from incoming spray and the weather.

H9.3 Construction and provisions

The first aid kit shall be stored in a weathertight, portable case of a non-corrosive material of suitable strength and size to accommodate the first aid stores.

The case should be fastened securely with quick-release closures.

H9.4 Labelling and Identification

The first aid kit case shall be labelled FIRST AID on the lid and at least two (2) sides for quick identification. The storage location of the first aid kit shall be clearly identified with an appropriate sign or sticker.

The contents shall be listed with a brief instruction for use for each item listed, along with expiry dates and the last check date. The list shall be stowed within or adjacent to the first aid kit.

H9.5 Maintenance

First aid kits shall be cleaned and checked every three (3) months.

H10 MEDICAL CABINET

H10.1 Application

All vessels covered by Scale D and E shall be provided with a medical cabinet of suitable size, design and construction for storing medical supplies.

NOTE: Storage of splints, neck collars, stretchers, etc may be separate from the medical cabinet; however, storage of these items should be readily accessible to the crew.

H10.2 Location

The medical cabinet shall be located either—

- a) in a separate compartment adjacent to the hospital accommodation;

- b) where hospital accommodation is not provided, adjacent to the vessel's officers' accommodation; or
- c) in a dry and cool space accessible to the Master and a nominated crew member.

H10.3 Construction and illumination

The medical cabinet shall be provided with—

- a) an outer door, fitted with an efficient lock;
- b) an inner cupboard, independently locked, for storing special drugs (noted in Scales by the symbols '*' or '#');
- c) a dispensing counter or table, with an impervious surface, which may be a shelf in the medical cabinet;
- d) suitable storage space for medicines and measuring devices, which facilitate identification of various items; and
- e) illumination by electric light from inside or immediately outside the cabinet.

H10.4 Labelling and identification

The medical cabinet shall be clearly identified on the outer door with an appropriate sign or sticker.

The contents of the medical cabinet shall be listed with a brief instruction for use for each item listed, along with expiry dates and the last check date. The list shall be stowed within or adjacent to the medical cabinet.

H10.5 Maintenance

Medical cabinets shall be cleaned and checked every three (3) months.

H11 FIRST AID TRAINING

Persons administering first aid should possess as a minimum a current first aid qualification in accordance with Marine Order 505.

NOTE: Certain items in these Scales may require additional training to administer:

1. Persons administering first aid using Scale D should have the competency of a Shipmasters Medical Qualification or an Advanced First Aid Certificate including training in administering injections (IMI and SCI), splinting with vacuum and air splints, and manual resuscitation.
2. Persons administering the supplies in Scale E First Aid Kits and medical supplies should possess a current First Aid Certificate or, more preferably the Occupational level of First Aid Certificate, First Aid Oxygen therapy, Asthma management, and the use of Air Splints.
3. Where a defibrillator unit is carried, SAE Defibrillation training should be undertaken.

Table H.2—Scales applicable to vessel class and operational area

Class	Vessel use and operational area	Extra specification	Scale and table
1 Passenger Vessel			
1A	Unlimited Domestic Operations (greater than 200 nm)	Nil	<i>Marine Order 11 (Living and working conditions on vessels) 2013</i>
1B	Offshore Operations (up to 200 nm)	berthed passengers	Scale D – Table H.4 & Table H.5
		unberthed	Scale D – Table H.4 & Table H.5
1C	Restricted Offshore Operations (up to 30 nm)	berthed passengers	Scale E – Table H.4 & Table H.5
		unberthed	Scale F – Table H.3
1D	Partially Smooth Water Operations (areas defined by jurisdictions)	berthed passengers	Scale F – Table H.3
		unberthed	Scale G – Table H.3
1E	Smooth Water Operations (areas defined by jurisdictions)	berthed passengers	Scale F – Table H.3
		unberthed	Scale G – Table H.3
2 Non-Passenger Vessel			
2A	Unlimited Domestic Operations (greater than 200 nm)	Nil	<i>Marine Order 11 (Living and working conditions on vessels) 2013</i>
2B	Offshore Operations (up to 200 nm)	Nil	Scale E – Table H.4 & Table H.5
2C	Restricted Offshore Operations (up to 30 nm)	Nil	Scale F – Table H.3
2D	Partially Smooth Water Operations (areas defined by jurisdictions)	Nil	Scale G – Table H.3
2E	Smooth Water Operations (areas defined by jurisdictions)	Nil	Scale G – Table H.3
3 Fishing Vessel			
3A	Unlimited Domestic Operations (greater than 200 nm)	Nil	<i>Marine Order 11 (Living and working conditions on vessels) 2013</i>
3B	Offshore Operations (up to 200 nm)	Nil	Scale E – Table H.4 & Table H.5
3C	Restricted Offshore Operations (up to 30 nm)	Nil	Scale F – Table H.3
3D	Partially Smooth Water Operations (areas defined by jurisdictions)	Nil	Scale G – Table H.3
3E	Smooth Water Operations (areas defined by jurisdictions)	Nil	Scale G – Table H.3

Table H.3— Scale G and F First Aid Kits

Description	Quantity		Notes	Comments
	Scale G	Scale F		
Bandage, conforming 5 cm	1	2		secure dressing and support injured parts
Bandage, conforming 10 cm	1	2		secure dressing and support injured parts
Bandage, heavy crepe 7.5 cm	2	2		support bandage
Bandage, heavy crepe 10 cm	-	1		support bandage, wide
Bandage, triangular	4	4		slings
Dressing, combine 10 x 10 cm, sterile	3	3	†	bleeding control
Dressing, combine 10 x 20 cm, sterile	2	5	†	bleeding control, large
Dressing, non-adherent (10 x 10 cm or similar)	5	10	†	wound cover
Dressing, hydroactive (10 x 10 cm or similar)	1	2	†	blisters, burns and minor exudate wounds
Wound dressing, combination, large	2	3		major wounds
Wound dressing, combination, small	2	2		major wounds
Adhesive roll non-woven fabric 5 cm x 10 m	1	1		securing dressings
Dressings, elastic fabric strips	50	50		minor wound cover
Gauze swabs, sterile (single use pkt of 3)	3	9	†	cleansing/dressing wound
Eye pad, sterile	2	4	†	eye cover
Wound closure strips, wide, 6 x 38 mm	1	3	†	securing wound sides
Tape surgical waterproof 2.5 cm x 5 m	1	1		secure dressing
Tape surgical waterproof 5 cm x 5 m	1	1		secure dressing
Towels, disposable, pkt of 2	2	3		
Plastic bag set (3 asst L, M and S)	1	2		amputated parts
Plastic bag	2	2		disposal of soiled dressings
Gloves, disposable, large	10	10		
Safety pins, stainless, assorted pkt of 12	1	1		
Blanket, emergency thermal	1	1		hypothermia and shock
Ice pack, instant	1	1		
Resuscitation mask, disposable	1	1		
Resuscitation mask, pocket	-	1		
Splinter probes, sterile, disposable	5	10		
Splinter forceps, 12.5 cm	1	1		
Shears, stainless, 19 cm minimum	1	1		

(Continued...)

Table H.3 cont.

Description	Quantity		Notes	Comments
	Scale G	Scale F		
Scalpel, disposable	-	2		
Splint malleable, universal	1	2		
Normal saline, sterile 30 ml polyamp	6	10	†	eye irrigation / wound cleaning
Povidone iodine swabs (single use)	10	20	†	antiseptic
Anaesthetic + antiseptic cream 30 g	1	1	†	
Hydrocortisone 1% cream 30 g	-	1	†	rashes & bites
Paracetamol 500 mg tabs or caps	20	2 x 20	†	mild pain relief
Paracetamol 500 mg / Codeine 8 mg	-	24	†	moderate pain relief
Ibuprofen 200 mg tablets	-	24	†	anti-inflammatory
Hyoscine hydrobromide 0.3mg tablets	10	10	†	seasickness
Loperimide 2mg tablets	16	16	†	diarrhoea
Loratadine HCl 10 mg or Fexofenadine HCl 120 mg tablets	-	10	†	antihistamine (non-sedating)
Antacid tablets	12	50	†	
CPR instruction chart or card	1	1		
Australian First Aid Book	1	1		

KEY:

† = Expiry dated

NOTE: It is recommended that Class 1 vessels also carry a SAE Defibrillator (Laerdal First Aid unit or similar), Stretcher for helicopter evacuation / ship board use and a First Aid Oxygen Unit (Oxyport or equal) in addition to the requirements for Scale F. These items will not fit into the First Aid Kit however storage of these items should be readily accessible to the crew.

Table H.4—Scale E and D Medication

Description	Quantity		Notes	Comments
	Scale E	Scale D		
Adrenaline 1-1000 1ml ampoules	-	5	†	sudden allergic reaction
Antibiotic ointment 15g or 20g	1	1	* †	infected wound
Amoxicillin 500mg caps	-	20	* †	oral antibiotic
Doxycycline 100mg caps or tabs	-	21	* †	oral antibiotic
Benzyl penicillin 600mg with WFI 2ml	-	5	* †	antibiotic injection
Chloramphenicol Eye Ointment 4g	1	1	* †	eye antibiotic
Glyceryl trinitrate 400mcg spray	1	1	†	angina/ heart pain
Morphine 10mg/ml ampoules	-	5	* † #	severe pain only with medical advice
Naloxone 0.4mg/ml minijet	-	5	* †	morphine antagonist
Paracetamol 500mg/Codeine 30mg tabs	20	20	* †	moderate-severe pain also cough suppression
Prochlorperazine 5mg tablet	25	25	* †	nausea, giddiness
Prochlorperazine 25mg suppositories	5	5	* †	vomiting, giddiness
Prochlorperazine 12.5mg/ml ampoules	-	10	* †	severe seasickness
Prednisolone 5mg tablet	-	20	* †	only with medical advice
Salbutamol inhaler	1	1	†	asthma attack
Sodium chloride and glucose or dextrose compound, powder sachets, 4.9g approx	10	20	†	rehydration

KEY:

† = Expiry dated

* = Requires prescription

= Requires separate locked storage and recording in controlled drug register

Table H.5—Scale E and D Medical Equipment

Description	Quantity		Notes	Comments
	Scale E	Scale D		
Scalpel, sterile, disposable	3	5		
Scissors, stainless, blunt/sharp 12.5 cm	-	1		
Splint set, vacuum or air inflation	1	1		
Neck collar, multi-size, rigid, fully adjustable	1	2		
Syringe with needle, sterile disposable 1 ml	-	5		
Syringe with needle, sterile, disposable 2 ml or 3 ml, 23 G or 25 G	-	5		
Isopropyl alcohol swabs	-	10		
BVM air resuscitator	1	1		
SAE Defibrillator (Laerdal First Aid unit or similar)	Optional	1		
Stretcher for helicopter evacuation / ship board use	Optional	1		
First Aid Oxygen Unit (Oxyport or equal)	Optional	1		
Ship Captain's Medical Guide, current edition	-	1		
Controlled Drug Register	-	1		

ANNEX I TRANSITIONAL ARRANGEMENTS FOR EXISTING VESSELS

I1 SCOPE

This Annex I modifies the deemed to satisfy solutions contained in Chapters 3 to 6 and Annexes A to H for existing vessels, as defined in *Marine Order 503 (Certificates of survey – national law) 2017*.

This Annex does not apply to transitional vessels, as defined in *Marine Order 503 (Certificates of survey – national law) 2017*.

An existing vessel will be deemed to have satisfied the required outcomes mentioned in Chapter 2 where:

- a) it complies with Chapters 3 to 6 and Annexes A to H of this Subsection; or
- b) it complies with Chapters 3 to 6 and Annexes A to H of this Subsection as modified by this Annex I.

This Annex is referenced in Clause 1.1 and 2.1 of this Subsection.

NOTE 1: Existing vessels, as defined in *Marine Order 503 (Certificates of survey – National Law) 2017*, are required to comply with this Subsection from 1 January 2018.

NOTE 2: Clauses I2 to I5 and Table I.1 provide transitional provisions for an existing vessel to comply with this Subsection.

NOTE 3: Transitional vessels, as defined *Marine Order 503 (Certificates of survey – National Law) 2017*, are required to comply with this Subsection but are not eligible for the transitional provisions contained in this Annex I.

I2 OBJECTIVE

The objective of this Annex is to specify the transition of existing vessels to an acceptable level of compliance with this Subsection in a way that is effective in maintaining the expectations for minimum levels of safety equipment for all domestic commercial vessels.

I3 REPLACEMENT SAFETY EQUIPMENT

Subject to I4 and Table I.1, in the event that any safety equipment on board an existing vessel requires replacing, it shall be replaced by equipment of the kind, quantity and standard mentioned in Chapters 3 and 5 and Annexes A to H as applicable to the kind and class of vessel.

NOTE 1: If Table I.1 provides that a requirement of this Subsection does not apply to specified existing vessels, the requirement does not apply even if the item is replaced.

NOTE 2: If Table I.1 provides that a requirement of this Subsection applies after a specified period, the vessel must meet the requirement on or before that date even if the item would not otherwise be replaced on or before that date.

I4 GENERAL PROVISIONS

In addition to I3, existing vessels shall comply with the deemed-to-satisfy solutions of this Subsection as modified by Table I.1.

The clause and clause title mentioned in columns 1 and 2 of table I.1 refer to the clauses in Chapters 3 to 6 and Annexes A to H in this Subsection.

15

EQUIVALENT REQUIREMENTS TO APPLY

If, under this Annex I, an existing vessel is not required to comply with a deemed to satisfy solution contained in Chapters 3 to 6 or Annexes A to H of this Subsection, either for a transitional period or at all, the equivalent requirement of either of the following standards applies for that period:

- a) the USL Code Section 10 or 13; or
- b) the standard that applied to the vessel immediately prior to the commencement of this Annex I.

NOTE: Annex I commenced on 1 January 2018.

Table I.1—Transitional Provisions for Existing Vessels

Clause number	Clause title	Summary of deemed to satisfy solution	Transitional requirement for existing vessels
Chapter 3 – Safety Equipment design and construction			
3.3.1, Table 1	Standards for Safety Equipment	Safety equipment shall comply with the standard mentioned in Table 1	On expiry or replacement of the current item of safety equipment, all replacement equipment is to comply with the standard mentioned in Table 1. NOTE: This repeats the requirement contained in clause I3
3.3.2	Assessment and verification	Safety equipment shall be assessed and verified as meeting the applicable standards using one or more of the methods mentioned in 3.3.2	Compliance required as equipment is acquired or replaced.
Chapter 4 – Installation of safety equipment			
4.3 General requirements			
4.3.1.1	Stowage of SOLAS equipment on Class A vessels	SOLAS life-saving appliances on Class A vessels shall be stowed in accordance with the requirements specified in Marine Order 25 (Equipment — life-saving) 2009 for Class A vessels over 500 gross tonnage.	Compliance required within 12 months from next periodic or renewal survey, or within 24 months from 1 January 2018, whichever occurs first.
4.3.1.2	Stowage above high-risk spaces	Safety equipment shall be stowed in accordance with 4.3.1.2	Equipment shall be relocated (where it does not meet the standard mentioned in 4.3.1.2) by the next periodic or renewal survey, or within 12 months from 1 January 2018, whichever occurs first. Where the vessel's configuration is such that it restricts the ability to relocate the equipment, the National Regulator may approve an alternative arrangement.
4.3.1.3	Marking of stowage locations	Stowage locations for safety equipment shall be marked in accordance with 4.3.1.3	Compliance required within 12 months from next periodic or renewal survey or within 24 months from 1 January 2018 whichever occurs first.
4.3.2.1	Embarkation	Requirements for means of embarkation	Compliance required within 12 months from next periodic or renewal survey, or within 24 months from 1 January 2018, whichever occurs first. Where the vessel's configuration or arrangement is such that it is impracticable to have embarkation

Clause number	Clause title	Summary of deemed to satisfy solution	Transitional requirement for existing vessels
			ladders (e.g. reduced freeboard) the National Regulator may approve an alternative arrangement.
4.3.2.2	Additional requirements for embarkation ladders	Where fitted embarkation ladders are to meet the standard mentioned in 4.3.2.2	Compliance required within 12 months from next periodic or renewal survey, or within 24 months from 1 January 2018, whichever occurs first.
4.3.2.3	Marine evacuation systems	Where fitted, marine evacuation systems (MES) shall comply with the requirements specified in Marine Order Part 25 (Equipment — life-saving) 2009 for Class A vessels over 500 gross tonnage	Compliance required where an existing marine evacuation system is replaced.
4.3.2.4	Overboard discharges	Means shall be provided to prevent any overboard discharges on to a survival craft during abandonment	Compliance required on 1 January 2018. NOTE: Compliance with the USL Code requirements for overboard discharges will satisfy the requirements of 4.3.2.4

4.4 Lifeboats and rescue boats

4.4.1	Parent vessel identification	Lifeboats and rescue boats shall be marked in accordance with 4.4.1	Compliance required when the parent vessel identification marking is replaced, or the lifeboat / rescue boat is replaced, whichever occurs first.
4.4.2	Stowage of lifeboats and rescue boats	Lifeboats and rescue boats shall to be stowed in accordance with 4.4.2	Compliance required within 12 months from next periodic or renewal survey, or within 24 months from 1 January 2018, whichever occurs first.
4.4.3	Launching and retrieval	Launching and retrieval of lifeboats and rescue boats shall be in accordance with 4.4.3 (including the assumed person weights and minimum factors of safety)	Compliance required on replacement of the lifeboat or rescue boat.
4.4.4	Illumination	Means shall be provided to ensure that lifeboats, rescue boats, their associated launching devices, and the area of water into which they will be deployed, shall be sufficiently illuminated	For Class 1 vessels only, compliance required within 12 months from next periodic or renewal survey, or within 24 months from 1 January 2018, whichever occurs first. Requirement does not apply to other vessels. NOTE: Vessels not required to comply with 4.4.4 must comply with the equivalent USL Code requirement – see clause I5.

Clause number	Clause title	Summary of deemed to satisfy solution	Transitional requirement for existing vessels
4.4.5	Operating instructions	Posters or signs shall be provided containing relevant instructions or warnings	Compliance required within 12 months from next periodic or renewal survey, or within 24 months from 1 January 2018, whichever occurs first.

4.5 Liferafts

4.5.1	Parent vessel identification	Liferafts shall be marked in accordance with 4.5.1	Compliance required when the parent vessel identification marking is replaced, or the liferaft is replaced, whichever occurs first.
4.5.2	Stowage of liferafts	Liferafts shall be stowed in accordance with 4.5.2.	Compliance required within 12 months from next out of water survey, or within 60 months from 1 January 2018, whichever occurs first.
4.5.3	Illumination	Means shall be provided to ensure that the stowage positions of liferafts, the launching devices (where fixed launching devices are used), and the areas of water into which the liferafts will be deployed shall be sufficiently illuminated	For Class 1 vessels only, compliance required within 12 months from next periodic or renewal survey, or within 24 months from 1 January 2018, whichever occurs first. Requirement does not apply to other vessels. NOTE: Vessels not required to comply with 4.4.4 must comply with the equivalent USL Code or other applicable requirement – see clause I5.
4.5.4	Operating instructions	Operating instructions for liferafts shall be provided in accordance with 4.5.4.	Compliance required within 12 months from next periodic or renewal survey, or within 24 months from 1 January 2018, whichever occurs first.

4.6 Dinghies

4.6.1	Parent vessel identification	Dinghies shall be marked in accordance with 4.6.1	Compliance required when the parent vessel identification marking is replaced, or the dinghy is replaced, whichever occurs first.
4.6.2	Stowage of dinghies	Dinghies shall be stowed in accordance with 4.6.2	Compliance required on 1 January 2018. <i>Note</i> Compliance with the USL Code requirements for stowage will satisfy the requirements of 4.6.2
4.6.3	Launching	Means shall be provided of launching dinghies in accordance with 4.6.3	Compliance required on replacement of dinghy.

Clause number	Clause title	Summary of deemed to satisfy solution	Transitional requirement for existing vessels
4.6.4	Illumination	Means shall be provided to ensure that the stowage positions of dinghies and the areas of water into which the dinghies will be deployed shall be sufficiently illuminated	Compliance required within 12 months from next periodic or renewal survey or within 24 months from 1 January 2018 whichever occurs first.

4.7 Buoyant appliances

4.7.1	Parent vessel identification	Buoyant appliances shall be marked in accordance with 4.7.1	Compliance required when the parent vessel identification marking is replaced, or the buoyant appliance is replaced, whichever occurs first.
4.7.2	Stowage of buoyant equipment	Buoyant appliances shall be stowed in accordance with 4.7.2	Compliance required within 12 months from next periodic or renewal survey, or within 24 months from 1 January 2018, whichever occurs first.
4.7.3	Illumination	Means shall be provided to ensure that the stowage positions of buoyant appliances shall be sufficiently illuminated. Means shall be provided to ensure that the areas of water into which the buoyant appliances will be deployed shall be sufficiently illuminated.	Compliance with the requirement to illuminate stowage positions of buoyant appliances in accordance with 4.7.3 is required within 12 months from next periodic or renewal survey, or within 24 months from 1 January 2018, whichever occurs first. The requirement mentioned in 4.7.3 to illuminate areas of water into which the appliances will be deployed does not apply to existing vessels.

4.8 Lifebuoys

4.8.1	Parent vessel identification	Lifebuoys shall be marked in accordance with 4.8.1	Compliance required when the parent vessel identification marking is replaced, or the lifebuoy is replaced, whichever occurs first.
4.8.2	Stowage of lifebuoys	Lifebuoys shall be stowed in accordance with 4.8.2	Compliance required within 12 months from next periodic or renewal survey, or within 24 months from 1 January 2018, whichever occurs first.

4.9 Lifejackets

4.9.1	Parent vessel marking	Lifejackets shall be marked in accordance with 4.9.1	Compliance required when the parent vessel identification marking is replaced, or the lifejacket is replaced, whichever occurs first.
4.9.2	Stowage of lifejackets	Lifejackets shall be stowed in accordance with 4.9.2	Compliance required within 12 months from next periodic or renewal survey, or within 24 months from 1 January 2018, whichever occurs first

Clause number	Clause title	Summary of deemed to satisfy solution	Transitional requirement for existing vessels
4.9.3	Stowage area information	Written and pictorial instructions to be provided	Compliance required within 12 months from next periodic or renewal survey, or within 24 months from 1 January 2018, whichever occurs first.

4.10 Pyrotechnic and smoke signals

4.10.1	Stowage and marking	Pyrotechnics and smoke signals shall be stowed and marked in accordance with 4.10.1	Compliance required within 12 months from next periodic or renewal survey, or within 24 months from 1 January 2018, whichever occurs first.
--------	---------------------	---	---

Chapter 5 – Type and quantity of safety equipment

5.3 Safety equipment to be carried

NOTE 1: Existing vessels must comply with the type and quantity requirements of tables 2, 3 and 4 when existing equipment expires or is replaced, unless otherwise specified in this table – see clause 13 above. This part of the table provides transitional timeframes and allowances where the type and/or quantity requirements of tables 2, 3 and 4 differ to the USL Code.

NOTE 2: Chapter 3, clause 5.4 also applies to relevant existing vessels when equipment is replaced or new equipment is acquired.

5.3, tables 2, 3 and 4	Liferafts and rescue boats – Anti-exposure suits	Anti-exposure suits shall be carried as required in tables 2, 3 or 4 (note R1 to the tables)	Compliance required by the next periodic or renewal survey, or within 12 months from 1 January 2018, whichever occurs first.
5.3, tables 2, 3 and 4	Liferafts and rescue boats – Inflatable liferafts	A dinghy is not permitted to be used as an alternative to an inflatable liferaft	For Class 3C vessels <25m, a dinghy may continue to be used as an alternative to an inflatable liferaft provided it meets the requirements of Annex C within 12 months from next periodic or renewal survey, or within 24 months from 1 January 2018, whichever occurs first. Where the existing dinghy being used in place of a liferaft is due for replacement, it shall be replaced by an inflatable liferaft of the kind and quantity mentioned in Table 4.
5.3, Table 2	Buoyant appliances (general) – Open reversible liferafts	Open reversible liferafts shall be carried in place of buoyant appliances as required in Table 2 (note B1 to Table 2) NOTE: This requirement applies to specified Class 1 vessels only	Compliance required within 12 months from next periodic or renewal survey, or within 24 months from 1 January 2018, or when buoyant appliances are replaced, whichever occurs first.
5.3, Table 2	Buoyant appliances (general) and lifebuoys	A vessel shall carry the kind and quantity of buoyant appliances and lifebuoys mentioned in Table 2	Compliance required as equipment is acquired or replaced, or within 48 months from 1 January 2018, whichever occurs first.

Clause number	Clause title	Summary of deemed to satisfy solution	Transitional requirement for existing vessels
5.3, tables 2, 3 and 4	Lifejackets	A vessel shall carry the quantity of lifejackets mentioned in tables 2, 3 or 4	Compliance required as equipment is acquired or replaced, or within 48 months from 1 January 2018, whichever occurs first.
5.3, tables 2, 3 and 4	Lifejackets	A vessel shall carry the kind of lifejackets mentioned in tables 2, 3 or 4	Compliance required as equipment is acquired or replaced.
5.3, tables 2, 3 and 4	Distress signals	A vessel shall carry the kind and quantity of distress signals mentioned in tables 2, 3 or 4	<p>Does not apply to vessels operating in operational area E except vessels in remote enclosed waters.</p> <p>For all other vessels and vessels in remote enclosed waters, compliance required within 12 months from next periodic or renewal survey, or within 24 months from 1 January 2018, whichever occurs first.</p> <p>NOTE: Vessels operating in operational area E, except remote enclosed waters, can continue to comply with the USL Code requirements for distress signals, instead of the NSCV requirements – see clause I5.</p>
5.3, Table 2	Rockets and lines	<p>A vessel shall carry the kind and quantity of rockets and lines mentioned in Table 2</p> <p>NOTE: This requirement applies to Class 1B and 1C vessels $\geq 45\text{m}$ only</p>	Compliance required within 12 months from next periodic or renewal survey, or within 24 months from 1 January 2018, whichever occurs first.
5.3, tables 2, 3 and 4	On board communications and alarm systems	On board communications and alarms system (public address system) required for specified Class 1 vessels, and on board alarm system for specified Class 2 and 3 vessels	Compliance required within 12 months from next periodic or renewal survey, or within 24 months from 1 January 2018, whichever occurs first.
5.3, tables 2, 3 and 4	Emergency lighting (hand held)	Two (2) battery-operated torches to be carried on board for vessels operating in operational area B.	Compliance required within 12 months from next periodic or renewal survey, or within 24 months from 1 January 2018, whichever occurs first.
5.3, tables 2, 3 and 4	Emergency lighting (hand held)	One (1) battery-operated torches to be carried on board for each crew member for vessels operating in operational areas C, D or E	Compliance required within 12 months from next periodic or renewal survey, or within 24 months from 1 January 2018, whichever occurs first.

Clause number	Clause title	Summary of deemed to satisfy solution	Transitional requirement for existing vessels
5.3, tables 2, 3 and 4	Medical supplies	Carriage of medicines and medical stores	Compliance required on replacement of items, or within 12 months from next periodic or renewal survey, or within 24 months from 1 January 2018, whichever occurs first.

Chapter 6 – Servicing of safety equipment

6.1 to 6.11	Servicing of safety equipment	Safety equipment shall be serviced in accordance with clauses 6.1 to 6.11.	Compliance required from the next service date of each item of safety equipment.
-------------	-------------------------------	--	--

Annex B - Requirements for non-SOLAS rescue boats

NOTE: All aspects of Annex B apply when equipment is replaced, or as otherwise specified in this table – see clause I3 above. This part of the table specifies requirements that may apply prior to replacement, depending on when equipment is replaced.

B5 Marking of rescue boats

B5.1	Retro-reflective tapes	Non-SOLAS rescue boats shall comply with clause B5.1.	Compliance required within 12 months from next periodic or renewal survey, or within 24 months from 1 January 2018, whichever occurs first.
------	------------------------	---	---

Annex C - Requirements for dinghies

C5 Marking

NOTE: All aspects of Annex C apply when equipment is replaced or as otherwise specified in this table – see clause I3 above. This part of the table specifies requirements that may apply prior to replacement, depending on when equipment is replaced.

C5.1	Retro-reflective tapes	Dinghies shall comply with clause C5.1.	Compliance required within 12 months from next periodic or renewal survey, or within 24 months from 1 January 2018, whichever occurs first.
------	------------------------	---	---

Annex D – Requirements for inflatable coastal liferafts

NOTE: All aspects of Annex D apply when equipment is replaced or as otherwise specified in this table – see clause I3 above. This part of the table specifies requirements that may apply prior to replacement, depending on when equipment is replaced.

D3	Equipment and rations	Equipment and rations carried in inflatable coastal liferafts shall comply with D3.	Compliance required from the next service date of each item of safety equipment. NOTE: Some liferafts may not have capacity in existing containers to accommodate this requirement. Where this is the case, the National Regulator will consider approving an alternative arrangement.
----	-----------------------	---	---

Clause number	Clause title	Summary of deemed to satisfy solution	Transitional requirement for existing vessels
---------------	--------------	---------------------------------------	---

Annex E - Requirements for open reversible liferafts

NOTE: All aspects of Annex E apply when equipment is replaced or as otherwise specified in this table – see clause I3 above. This part of the table specifies requirements that may apply prior to replacement, depending on when equipment is replaced.

E3 Fittings

E3.2	Hydrostatic release unit	Open reversible liferafts shall be fitted in accordance with E3.2	Compliance required on replacement of the hydrostatic release unit.
------	--------------------------	---	---

Annex F - Requirements for buoyant appliances

NOTE: All aspects of Annex F apply when equipment is replaced or as otherwise specified in this table – see clause I3 above. This part of the table specifies requirements that may apply prior to replacement, depending on when equipment is replaced.

F2 Design and construction

F2.6	Painter	Buoyant appliances shall be fitted with a painter in accordance with F2.6.	Compliance required within 12 months from next periodic or renewal survey, or within 24 months from 1 January 2018, whichever occurs first.
F2.6.1	Painter attachment point	Painters for buoyant appliances shall be in accordance with F2.6.	Compliance required within 12 months from next periodic or renewal survey, or within 24 months from 1 January 2018, whichever occurs first.

Annex H – Requirements for medical supplies

H3 General

H3.2	Equipment and supplies to be carried	Equipment supplies shall be in accordance with H3.2. NOTE: This includes the kind, quantity, scale and standard of medical equipment and supplies	Compliance required on replacement of items, or within 12 months from next periodic or renewal survey, or within 24 months from 1 January 2018, whichever occurs first.
------	--------------------------------------	--	---