

DRAFT-IN-CONFIDENCE



**Australian Government**

**Australian Maritime Safety Authority**

**National Standard for Commercial Vessels**

**Part C – Design and construction**

**Section 1 – Wheelhouse visibility, escape, accommodation, and personal safety**

**Edition 2.0**

**External Consultation draft**

External Consultation Draft

Edition 2

Edition 2 was first published on xx January 2023.

Edition 2 was adopted by the Infrastructure and Transport Council on xx November 2022 to commence on xx xxxx xxxx.

Previous editions of NSCV Section C1 include:

- Edition 1.2, which was approved by the National Marine Safety Regulator on 23 July 2018 and commenced 24 July 2018.
- Edition 1.1, which was approved by the National Marine Safety Regulator on 7 June 2016 and commenced 10 June 2016.
- Edition 1, which was approved by the Standing Council on Transport and Infrastructure on 15 November 2013, and first published on 18 November 2013.

### Copyright



© Australian Maritime Safety Authority 2021. The Australian Maritime Safety Authority encourages the dissemination and exchange of information provided in this publication.

Except as otherwise specified, all material presented in this publication is provided under Creative Commons Attribution 4.0 International licence. This excludes:

- the Commonwealth Coat of Arms
- this department's logo
- content supplied by third parties.

The Creative Commons Attribution 4.0 International Licence is a standard form licence agreement that allows you to copy, distribute, transmit and adapt this publication provided that you attribute the work. The details of the version 4.0 of the licence are available on the Creative Commons website, as is the full legal code for that licence.

### Attribution

The Australian Maritime Safety Authority's preference is that you attribute this publication (and any material sourced from it) using the following wording: Source: Australian Maritime Safety Authority

Published by Australian Maritime Safety Authority, GPO Box 2181 Canberra, ACT 2601. All enquiries to be addressed to the Executive Director, Policy and Regulation, Australian Maritime Safety Authority.

### Disclaimer

The Australian Maritime Safety Authority accepts no liability for the accuracy of the information nor its use or the reliance placed on it.

## FOREWORD

This Section of the National Standards for Commercial Vessels (NSCV) was developed following a review of the Uniform Shipping Laws (USL) Code.

External Consultation Draft

# CONTENTS

<b>CHAPTER 1 PRELIMINARY .....</b>	<b>7</b>
1.1 Scope.....	7
<b>1.2 Structure of this Section.....</b>	<b>7</b>
1.3 Application .....	7
1.4 Referenced documents.....	7
1.5 Definitions .....	9
<b>CHAPTER 2 REQUIRED OUTCOMES .....</b>	<b>13</b>
2.1 Meeting the required outcomes.....	13
2.2 The required outcomes .....	13
<b>CHAPTER 3 OPERATING STATIONS.....</b>	<b>18</b>
3.1 Application .....	18
3.2 Location of the operating position .....	18
3.3 Class 1 (passenger) vessel of measured length at least 24 m .....	18
<b>3.4 Field of vision from the primary operating station .....</b>	<b>18</b>
3.5 Glazing materials and tinting of windows used for navigation.....	25
3.6 Operating station layout, design and arrangement of navigational systems and equipment .....	25
<b>CHAPTER 4 ACCOMMODATION SPACES .....</b>	<b>27</b>
4.1 Application .....	27
4.2 Accommodation level.....	27
4.3 Requirements for accommodation spaces.....	27
4.4 Headroom .....	29
4.5 Control of vermin and disease .....	29
4.6 Ventilation .....	29
4.7 Temperature control.....	30
4.8 Lighting .....	31
4.9 Noise and vibration .....	31
4.10 Requirements for crew and <b>special personnel accommodation</b> .....	31
4.11 Crew sleeping <b>arrangements</b> .....	32
4.12 Berths for crew .....	34
4.13 Deck area for passengers.....	35
4.14 Seating accommodation for passengers.....	36

4.15	Sleeping accommodation for passengers	39
4.16	Vessels considered public transport must be accessible to persons with disabilities	39
4.17	Facilities for sick or injured persons	40
4.18	Recreational and mess facilities for crew and special personnel	40
4.19	Galley and food storage facilities	40
4.20	Sanitary facilities	41
4.21	Crew cloak and laundry facilities	43
4.22	Potable water	44
<b>CHAPTER 5 ESCAPES AND EVACUATION</b>		<b>46</b>
5.1	Application	46
5.2	General escape requirements	46
5.3	Escape from spaces	46
5.4	Design of escapes serving a space	48
5.5	Arrangement of escapes in accommodation spaces	52
5.6	Evacuation paths	53
5.7	Alternative means of evacuation by analysis	54
5.8	Assembly stations	54
5.9	Survival craft embarkation stations	55
5.10	Doors and hatches in escape or evacuation routes	55
5.11	Passageways	56
5.12	Handrails	57
5.13	Walkways, stairways and ladders – general requirements	58
5.14	Stairways	59
5.15	Ladders	61
5.16	Safety information and escape marking	63
5.17	Instruction for safe escape	64
<b>CHAPTER 6 PERSONAL SAFETY</b>		<b>66</b>
6.1	Application	66
6.2	Protection of persons from the elements	66
6.3	Safe movement of persons on vessels	67
6.4	Bulwarks and guardrails	67
6.5	Nominated special purpose and special working decks	70
6.6	Slip resistant surfaces	71

6.7	Foot stops and toe rails.....	72
6.8	Handholds.....	72
6.9	Harnesses, safety lines, clipping points and jack-stays .....	73
6.10	Reboarding .....	75
6.11	Hazardous plant.....	75
<b>6.12</b>	<b>Access to and from the vessel</b> .....	75
<b>6.13</b>	<b>Gangways and accommodation ladders</b> .....	76
6.14	Pilot transfer arrangements.....	77
6.15	Pilot launches.....	77
<b>ANNEX A</b>	<b>...METHODOLOGY FOR DETERMINING THE MINIMUM REQUIRED AGGREGATE WIDTH OF DOORS, STAIRWAYS, CORRIDORS AND WALKWAYS SERVING A SPACE .....</b>	<b>81</b>
<b>ANNEX B</b>	<b>...MARKING AND SIGNAGE.....</b>	<b>86</b>

# CHAPTER 1 PRELIMINARY

## 1.1 Scope

NSCV Section C1 provides the design, construction, installation and maintenance standards for wheelhouse visibility, escape, accommodation and personal safety on vessels.

## 1.2 Structure of this Section

- (1) Chapter 2 specifies the required outcomes. Chapter 3 through to Chapter 7 specify the deemed to satisfy solutions for meeting the required outcomes.
- (2) Annex A specifies the deemed to satisfy methodology for determining the minimum required aggregate width of doors, stairways, corridors and walkways serving a space.
- (3) Annex B specifies the deemed to satisfy solutions for escape and evacuation signage and marking, on low complexity vessels.

NOTE 1 NSCV Part B provides for approved equivalent means of compliance if a vessel complies with a standard not mentioned in this Section that is equivalent to the relevant deemed to satisfy solution(s).

NOTE 2 This section should be read in conjunction with NSCV Part B and NSCV Part C Section 4.

NOTE 3 Additional arrangement and accommodation requirements may apply under occupational health and safety legislation and legislation covering access for persons with disabilities

## 1.3 Application

- (1) This standard applies to all domestic commercial vessels except:
  - (a) special vessels as defined in NSCV Part F Special vessels (Part F), which must comply with Part F and are not required to comply with this section unless Part F specifies otherwise; and
  - (b) non-survey vessels as defined in NSCV Part G Non-survey vessels (Part G), which must comply with Part G and are not required to comply with this section unless Part G specifies otherwise.

## 1.4 Referenced documents

Each document mentioned in the following table is:

- (a) referenced in this Section; and
- (b) the latest revision of the document, including amendments, unless stated otherwise.

NOTE NSCV Part B provides that national, regional or international standards adopted or incorporated by reference in the NSCV are adopted or incorporated by reference as in force from time to time.

<b>Publisher</b>	<b>Document</b>
Australian Maritime Safety Authority	<i>National Standard for Commercial Vessels (NSCV)</i> <i>Part B—General Requirements</i> <i>Part C—Design and Construction</i> <i>Part F—Special Vessels</i>
Commonwealth of Australia	<i>Disability Discrimination Act 1992</i> <i>Disability Standards for Accessible Public Transport Guidelines 2004</i> <i>Disability Standards for Accessible Public Transport 2002</i>
International Labour Organization	<i>Maritime Labour Convention 2006 (MLC 2006)</i> <i>Code of Practice: Safety and health in ports</i>
International Maritime Organization	<i>Code on Noise Levels On Board Ships 2012</i> <i>The International Regulations for Preventing Collisions at Sea 1972 (COLREGS)</i> <i>Fire Safety Systems Code</i> <i>International Convention on Load Lines (Load Lines Convention)</i> <i>International Convention for the Safety of Life at Sea (SOLAS)</i> <i>IMO Resolution A.1116(30) Escape Route Signs and Equipment Location Markings</i> <i>LSA Code – International Life-Saving Appliance Code – Resolution MSC.48(66)</i>
International Organization for Standardization	<i>ISO 15085:2003 — Small craft — Man-overboard prevention and recovery</i> <i>ISO 11591:2020 – Small craft – Field of vision from the steering position</i> <i>ISO 15370:2021 - Low Location Lighting (LLL)</i> <i>ISO 7061:2015 — Shipbuilding — Aluminium shore gangways for seagoing vessels</i> <i>ISO 5488:2015 Ships and marine technology - Accommodation ladders</i> <i>ISO 8468 Ships and marine technology – Ships bridge layout and associated equipment – Requirements and guidelines</i> <i>ISO 12401:2209 Small craft – Deck safety harness and safety line – Safety requirements and test methods</i> <i>ISO 2240 series</i> <i>BS EN (ISO) 14203: 2003 Inland navigation vessels. Gangways for passenger vessels</i>



Publisher	Document
	<i>DS EN (ISO) 526:1995 Inland navigation vessels. Gangways with a length not exceeding 8 m</i>
	<i>EN 795: 2012 Personal fall protection equipment – Anchor devices</i>
Lloyd's Register	<i>Rules and Regulations for the Classification of Ships (Lloyd's Rules)</i>
Safe Work Australia	<i>Code of Practice – Managing noise and preventing hearing loss at work</i>
	<i>Code of Practice - Managing the work environment and facilities</i>
	<i>Code of Practice – Managing the risk of falls at the workplace</i>
Standards Australia	<i>AS1319 Safety Signs for the Occupational</i>
	<i>AS 1657-2018 — Fixed platforms, walkways, stairways and ladders — Design, construction and installation</i>
	<i>AS 1428.1-2021 — Design for access and mobility — Part 1: General requirements for access — New building work</i>
	<i>AS/NZS 2080-2006 — Safety Glazing for Land Vehicles</i>
	<i>AS 2227-2006 — Yachting harnesses and lines — Conventional lines</i>

## 1.5 Definitions

(1) In this Section:

**accommodation ladder** means a step ladder with flat or curved steps and handrails, enabling a person to embark or disembark the vessel.

**berthed passenger** means a passenger that is on board a vessel for a period of greater than 36 hours or that has otherwise been assigned a berth

**clear deck area** means deck space that is unencumbered and available for use by passengers and crew and excludes seats, tables and furniture.

NOTE Fixed seating in limited circumstances may be included in clear deck area in accordance with section 4.13(3).

**embarkation station** means a location on a vessel intended for the orderly and rapid embarkation of persons into survival craft.

**enclosed areas or spaces** means an enclosed space that is, or may be, fitted with a deckhead; and has means, either temporary or permanent, for side or end screens to be fitted around the area or space.

EXAMPLES of enclosed areas and spaces include:

- Spaces included in Table 15;
- The fully enclosed internal passenger seating area on a commuter ferry

**escape** means movement of personnel away from the immediate vicinity of a hazard to a designated place of safety on board the vessel.

**EXAMPLE** The movement of personnel from compartments or areas through normal accesses to assembly stations or embarkation stations.

**evacuation path** means a path:

- (a) nominated to facilitate the orderly and rapid movement of persons to an embarkation station; and
- (b) that starts at each point at which escape routes from different spaces merge.

**gangway** means a **passageway** or walkway used as a removable footway between a vessel and the shore intended for deployment for embarkation and disembarkation of persons and small cargo that can be carried.

**general purpose deck** means an open deck that is neither a special purpose deck nor a special working deck.

**high-capacity escape** means an escape of a type that facilitates rapid movement of persons (eg full height openings in boundaries leading to adjacent spaces, stairways or walkways).

**low-capacity escape** means an escape that has limited capacity to facilitate rapid movement of persons (eg narrow full height openings or restricted height openings leading to adjacent spaces, stairways or walkway, hatches, windows, portlights or side scuttles with ladder access if necessary).

**headroom**, for a space, means the height remaining in the space after deducting beams, deck-head linings, floor coverings and light fittings.

**operating position** means the location in an operating station that the person responsible for navigating the vessel would be expected to occupy when undertaking his or her functions under normal conditions of operation.

**NOTE 1** The operating position may be remote from the helm on a vessel that has a separate helmsman.

**NOTE 2** On a vessel not having a separate helmsman, the operating position is also the steering position.

**operating station** means any location on a vessel:

- (a) that is equipped with the necessary means for navigation, manoeuvring and communication; and
- (b) from where the functions of navigating, manoeuvring, communication, commanding, conning and lookout are carried out.

**operational workspace** means an enclosed space that:

- (a) is normally accessible to persons during normal operation of the vessel; and
- (b) is not an accommodation space.

**passageway** means an aisle that:

- (a) is set aside for the passage of persons past furniture and fittings within a space; and
- (b) is not enclosed by bulkheads on both sides.

**primary access** means the means of access used when the vessel is in normal operation

**primary steering position** means a steering position, within a primary operating station, that complies with the requirements for field of vision from the operating position mentioned in clause 3.4.

**primary operating station** means an operating station that complies with the requirements for field of vision mentioned in 3.4

**rung** means the step of a rung ladder or step on the vertical surface.

**secondary steering position** means a steering position that:

- (a) is not a primary steering position; and
- (b) is intended for a specific navigation function or for the special purpose of the vessel.

**special purpose deck** means an open deck:

- (a) that can be accessed by passengers; and
- (b) that is used for the special purpose of the vessel; and
- (c) for which full height bulwarks would significantly interfere with the special purpose or cause safety risks from the special purpose.

**EXAMPLE of vessels that may have a special purpose deck:**

- A boarding platform for snorkelling and diving operations
- Foredeck on a sailing vessel.

**EXAMPLE of a vessel that does not have a deck that meets the definition of a special purpose deck:**

- Whale and dolphin watching ecotourism vessels.

**special working deck** means an open deck:

- (a) for which full height bulwarks or guardrails would significantly interfere with the special purpose of the vessel or cause safety risks arising from the special purpose; and
- (b) that is only accessed by crew or special personnel.

**EXAMPLE of vessels that may have a special working deck:**

- Commercial net fishing vessels
- Tugs and vessels engaged in towing operations

**spiral stairway** means a stair with a circular plan, comprised of tapered treads that radiate from a common centre or several radii.

**stringer** means the frame of a ladder.

**winders** means tapered treads within a straight flight that are used to change direction of the stair.

**steering position** means the location in the operating station where the means for controlling the vessel during navigation are located.

**tapered tread** means a stair tread with a walking area that grows smaller towards an end.

**toilet (marine)** means a fixed or secured toilet or receptacle into which a person may urinate or defecate, typically consisting of a large bowl connected to a system for flushing (electric or manual pump) away the waste into an appropriate sewage treatment system or temporary holding tank.

**tread** means the step of a step ladder.

**voyage** means a journey by water, for the duration of time a person remains on the vessel without disembarking and returning to shore. It includes the time taken to load and unload the vessel while it is berthed or docked.

NOTE For the purposes of NSCV Section C1, the definition of voyage is intended to cover the time during which a passenger, member of crew or special personnel may be onboard a vessel without access to shore-based facilities.

**walkway** means a passageway that is either level or sloping from the surrounding floor or level, including a continuous structure or steps with landings.

- (2) In this Section, the following terms have the meaning given by the Dictionary in NSCV Part B:

<b>accommodation spaces</b>	<b>operational area</b>
<b>crew</b>	<b>operational area categories</b>
<b>depth</b>	<b>owner</b>
<b>fast craft</b>	<b>passenger</b>
<b>fish</b>	<b>passenger vessel</b>
<b>fishing vessel</b>	<b>risk</b>
<b>hazard</b>	<b>service categories</b>
<b>hire and drive vessel</b>	<b>sheltered waters</b>
<b>length</b>	<b>special personnel</b>
<b>maximum speed</b>	<b>superstructure</b>
<b>measured length</b>	<b>vessel</b>
<b>non-passenger vessel</b>	<b>vessel use categories</b>

## CHAPTER 2 REQUIRED OUTCOMES

### 2.1 Meeting the required outcomes

- (1) The vessel must be designed, constructed, arranged, maintained and serviced so that the required outcomes mentioned in clause 2.2 that apply to the vessel are met.
- (2) The required outcomes are met if the deemed to satisfy solutions contained in chapters 3 to 7 that apply to the vessel are met.

### 2.2 The required outcomes

#### Operating stations (Chapter 3)

#### A. Perception and situational awareness

A vessel must be arranged to ensure obligations under COLREGS are met. The person operating the vessel must have sufficient information to identify navigational hazards, assess the risks and take appropriate measures to control the risks in both normal and abnormal conditions of operation.

#### B. Human factors

A vessel's operating station must be arranged with human capabilities in mind to ensure safe operations, reduce the likelihood of error, enhance comfort, reduce fatigue and increase efficiency.

#### Accommodation, recreational facilities, food and catering (Chapter 5)

#### C. Minimum clear height between decks

The space between deck and deck head on a vessel must be sufficient:

- (a) for persons to avoid head or neck injury from accidental physical contact with the deckhead, deck beams or other items that project below the deck head; and
- (b) to allow the rapid movement of persons along escape and evacuation routes if there is an emergency.

#### D. Passenger and crew spaces

A vessel's passenger and crew spaces must be designed and arranged to:

- (a) minimise the risk of injury to occupants during normal vessel motions and during emergency conditions which can result in excessive vessel motions;
- (b) allow for the quick escape from hazards within the spaces and provide sufficient free space to allow occupants to move away quickly from the immediate vicinity of any hazards that might develop within the space;
- (c) ensure the safe movement of persons and provide sufficient free space to allow the movement of persons to occur without undue physical contact with other persons in the space; and

- (d) ensure heavy items of equipment are securely fastened in place to prevent movement during severe vessel motions in order to minimise the risk of injury to occupants.

#### **E. Berthed accommodation**

For a vessel with berthed accommodation, the accommodation must be designed and arranged to:

- (a) provide an environment that facilitates the rest and sleep of crew members and passengers;
- (c) facilitate the prevention of the spread of disease and minimise other risks to health;
- (d) provide sufficient personal space in sleeping accommodation to minimise interference that may compromise the harmony between persons on board the vessel; and
- (e) maintain social harmony, particularly where crew are expected to live on board for extended periods.

#### **F. Sanitary arrangements**

A vessel's sanitary arrangements must be designed and arranged:

- (a) so that persons on board can access toilet facilities without engaging in hazardous behaviour;
- (b) to promote hygienic behaviour through sufficient and appropriate toilet and washing facilities;
- (c) protect the privacy of a person using the sanitary facilities; and
- (d) to prevent the growth and transmission of micro-organisms by:
  - (i) ensuring that human waste is collected, transported and disposed of in a manner that protects the health of persons and prevents the transmission of disease; and
  - (ii) ensuring the regular and effective cleaning of sanitary facilities, avoiding the build up of unsanitary substances on sanitary facilities and promoting sanitary device use.

EXAMPLE OF HAZARDOUS BEHAVIOUR: Leaning over rails and bulwarks, or being exposed to the force of the sea.

#### **G. Galley and food storage facilities**

For a vessel on extended voyages without access to land-based facilities, the vessel must have a cooking area, food storage facilities and food waste facilities that are appropriate for the number of persons on board the vessel.

#### **H. Medical care on board vessels**

Larger vessels engaged in offshore operations and beyond, which do not have readily available access to land based medical care and facilities, must have adequate facilities on board for sick or injured persons.

## I. Vessel potable water arrangements

A vessel must have sufficient potable water for each person on board, taking into account the duration of the voyage and access to additional potable water or facilities to supply additional potable water. All made or supplied water must be stored in a manner which ensures that it remains potable.

Exits, escapes and evacuation (Chapter 6)

## J. Exits, escapes and evacuation

A vessel's access, exits and escapes must be designed and arranged to:

- (a) provide escape routes of sufficient number and size to eliminate or reduce to acceptable levels the exposure of persons on board the vessel to hazards such as fire, smoke and flooding;
- (b) provide alternative escape routes that control the risk of entrapment from the blocking of a single escape, having regard to the magnitude of risk if the escape route is blocked (eg the likelihood and consequences of exposure to hazards);
- (c) facilitate in an emergency the orderly and timely movement of persons:
  - (i) between decks;
  - (ii) to places of assembly; and
  - (iii) to disembarkation points for evacuation into survival craft;
- (d) facilitate movement between different deck levels in a way which avoids tripping hazards;
- (e) accommodate all persons onboard including when they are wearing a lifejacket of the type required to be provided on board the vessel.

**NOTE** Designers are expected to discuss with the owner the range of potential users and make any design limitations clear to the owner who will manage the embarkation, exit and evacuation process through the SMS.

- (f) ensure that exits, evacuation routes, escapes and their means of opening are adequately marked for the guidance of all persons onboard. Signage and symbols must promote rapid identification and interpretation allowing persons to move quickly in the event of emergency. Designers are expected to discuss with the owner the range of potential users and make any design limitations clear to the owner who will manage the embarkation, exit and evacuation process through the SMS.

**EXAMPLE** A person's language capabilities should not be a barrier to understanding.

Personal safety (Chapter 7)

## K. Protection of persons from the elements

A vessel must be designed and arranged to provide adequate protection from the sea and weather for persons on board the vessel and:

- (a) reduce to acceptable levels the risk to persons from being physically injured because of exposure to seas that might come onto the deck of the vessel; and
- (b) minimise the adverse health and fatigue effects on persons that arise from being exposed for extended periods to extremes of weather.

**L. Bulwarks and guard rails**

A vessel's bulwarks and guard rails must be designed and arranged to:

- (a) eliminate or reduce to acceptable levels the risk of persons falling overboard taking into account the competence and physical characteristics of the persons;
- (b) eliminate or reduce to acceptable levels the risk of a person falling from elevated locations taking into account the competence and physical characteristics of a person; and
- (c) prevent a person lying on the deck from falling (either overboard or from elevated locations) due to seas on deck, excessive deck angles or excessive accelerations.

**M. Protection of the crew and passengers from machinery and hazards**

A vessel must be provided with measures to eliminate or reduce to acceptable levels the risks:

- (a) to persons from hazards arising from machinery operating on the vessel;
- (b) associated with fall and slip hazards; and
- (c) of hearing damage generated by noise.

**N. Safe access to and from vessels**

A vessel must have safe means for a person to board, or disembark from, the vessel to a wharf, to another shoreside location, to another vessel or to an appropriate structure, taking into account:

- (a) variations in wharf height;
- (b) tidal range;
- (c) movement of the vessel due to waves, wind or current;
- (d) the surfaces to which a person is likely to require access;
- (e) the type of vessel; and
- (f) the needs of all likely users.

NOTE The designer is expected to complete a user needs analysis with the owner or operator to ensure the capabilities of the user are represented in the design.

**O. Vessels considered public transport must be accessible to people with disabilities**

A vessel considered to be public transport must be arranged to be accessible to people with disabilities



NOTE 1 The Disability Discrimination Act (DDA) makes it against the law for public places to be inaccessible to people with a disability.

**P. Vessel to vessel transfer and pilot transfer arrangements**

If the transfer of a person or a pilot from a vessel to another vessel is likely or envisaged, a safe means for affecting the transfer must be provided.

**Q. Pilot launch design and equipment**

A pilot launch on a vessel must be designed, fitted and equipped to ensure safe operation and safe pilot transfer.

**R. Recovery of persons who fall overboard**

A vessel must have the means to enable a person overboard to be recovered on board quickly and efficiently without the person being exposed to additional risks.

External Consultation Draft

## CHAPTER 3 OPERATING STATIONS

### 3.1 Application

This Chapter applies to each operating station on a vessel.

### DEEMED TO SATISFY SOLUTIONS

### 3.2 Location of the operating position

The operating position must:

- (a) allow the operator to conveniently and rapidly control the heading, speed and direction of the vessel while remaining alert for navigational hazards; and
- (b) be located and arranged to **suit the crew stature range** mentioned in Table 1.

**Table 1 — Requirements for vertical eye positions above the deck**

	<b>Standing: (including 20 mm footwear) above deck (mm)</b>	<b>Seated: above the surface of the compressed seat (mm)</b>
High eye position	1770	860
Low eye position	1550	745

### 3.3 Class 1 (passenger) vessel of measured length at least 24 m

**On a Class 1 vessel of measured length at least 24 m, the primary operating station:**

- (a) must be separated from passenger spaces; and
- (b) must not be used for purposes other than navigation, communications, provision of watchkeeper amenities or other functions essential to the safe operation of the craft, its engines, passengers and cargo.

### 3.4 Field of vision from the primary operating station

**(1) The primary operating station on the vessel must comply with either:**

- (a) Table 2, and Figure 1,**

- (b) Figure 2 and Figure 3 as applicable to the vessel, when the vessel is at both the lightest and heaviest design draft and throughout the range of operational trims; or
  - (c) for vessels <24m, ISO 11591 Small craft – Field of vision from the steering position.
- (2) If the vessel can be operated from both the seated and standing positions, but can only meet the standard from either the standing position or the seated position, a clearly visible notice must be attached to the operating position which informs the operator that visibility is limited from the standing or seated position, as applicable.

**Table 2 — Field of vision from the primary operating on vessels**

Item	Criteria <24m Vessels	Criteria ≥24m Vessels
<b>View forward from operating position</b>		
3.4.1	<p>The view of the sea surface from the operating position must not be obscured for a distance of more than;</p> <ul style="list-style-type: none"> <li>a) <math>L_m \leq 12.5</math> m four times the vessel's measured length</li> <li>b) <math>L_m &gt; 12.5</math> m to <math>\leq 25</math> m; 50 m.</li> <li>c) <math>L_m &gt; 25</math> m twice the vessel's measured length</li> </ul> <p>The view must be clear for at least 15° on either side of the bow under all conditions of draft, trim and deck cargo (see figure 3 ).</p>	
3.4.2	<p>Outside the clear sector of visibility from the operating position throughout the horizontal arc measured from 112.5° to port and 112.5° to starboard, obstructions must be kept to a minimum such that normal movements of the operator's head will permit unobstructed visibility (see Figure 2).</p>	<p>The clear sectors between blind sectors must be at least 5°.</p>
3.5.3	<p>Not applicable.</p>	<p>Framing between operating compartment windows must not be installed immediately forward of any operating position.</p>
<b>Horizontal field of vision</b>		
3.5.4	<p>The horizontal field of vision from the eye position at the operating position must be provided throughout a horizontal arc of at least 112.5° on the starboard side to 112.5° on the port side of the vessel (see Figure 2). For port side, starboard side or centreline steering position, these angles of vision to port and starboard are required without the operator leaving the steering position.</p>	
3.5.5	<p>Permanent and removable obstructions to vision must be such that clear vision from the eye position can be maintained with normal</p>	

	movement of the operator while maintaining control of the craft.	
3.5.6	A blind sector caused by cargo, cargo gear or other obstructions outside the operating compartment forward of the beam that obstructs the view of the sea surface as seen from the operating position must not exceed 10°.	
3.5.7	The total arc of blind sectors forward of the beam must not exceed 20°.	
3.5.8	Framing between operating station windows must be kept to a minimum.	
3.5.9	From the main steering position, the horizontal field of vision must extend over an arc from right ahead to at least 60° on each side of the vessel.	
<b>Vertical field of vision from the operating position</b>		
3.5.10	There must be no obstruction to obscure the forward view mentioned in item 3.4 when viewed from the low eye position mentioned in Table 1.	
3.5.11	Not applicable.	The upper edge of any operating compartment front windows, awning or other similar obstruction must allow a forward view of the horizon, for a person with a height of eye of 1770 mm above the deck at the operating position, when the vessel is pitching in heavy seas.
<b>View to the sides of the vessel</b>		
3.5.12	Not applicable.	The operating station must be arranged with at least 1 location on each side that provides a horizontal field of vision extending over an arc at least 225°, from at least 45° on the opposite bow through right ahead and then from right ahead to right astern through 180° on the same side of the vessel.
3.5.13	At the least operational draft, the sea surface at a transverse distance of 1,500 mm from the maximum beam throughout a vessel length along each side must be visible from a location in the operating station.	At the least operational draft, the side of the vessel on each side must be visible from a location in the operating station.
<b>Field of vision astern</b>		
3.5.14	If permanent obstructions to vision exist in the aft 135° sector of visibility, unobstructed visibility must be provided while maintaining control of the vessel by alternative means.  Examples may include: 1. Normal movement of the operator; 2. Mirrors.	
<b>Operating station windows</b>		
3.5.15	Not applicable.	The front windows of any operating compartment must be inclined from the vertical plane top out, at an angle of at least 10° and not more than 25°.

3.5.15	<p>Polarised and tinted windows must not be fitted in the operating compartment within the forward-facing sector defined by:</p> <p>(a) the horizontal arc from directly forward to 112.5° on the starboard side; and</p> <p>(b) the horizontal arc from directly forward to 112.5° on the port side.</p>	<p>Polarised or tinted windows must not be fitted to windows in the operating compartment.</p>
3.5.17	<p>A means must be provided for maintaining a clear view at all times, regardless of weather conditions, through at least 1 of the front windows of an operating compartment.</p>	<p>A means must be provided for maintaining clear vision at all times, regardless of weather conditions, through at least 2 of the front windows of an operating compartment. The 2 windows must be located so that the clear view is readily obtained from:</p> <p>(a) the operating position; and</p> <p>(b) if the steering position is not the same as the operating position — the steering position.</p>

**Figure 1 — Field of vision for vessels <24m from the operating station (clause 3.4)**

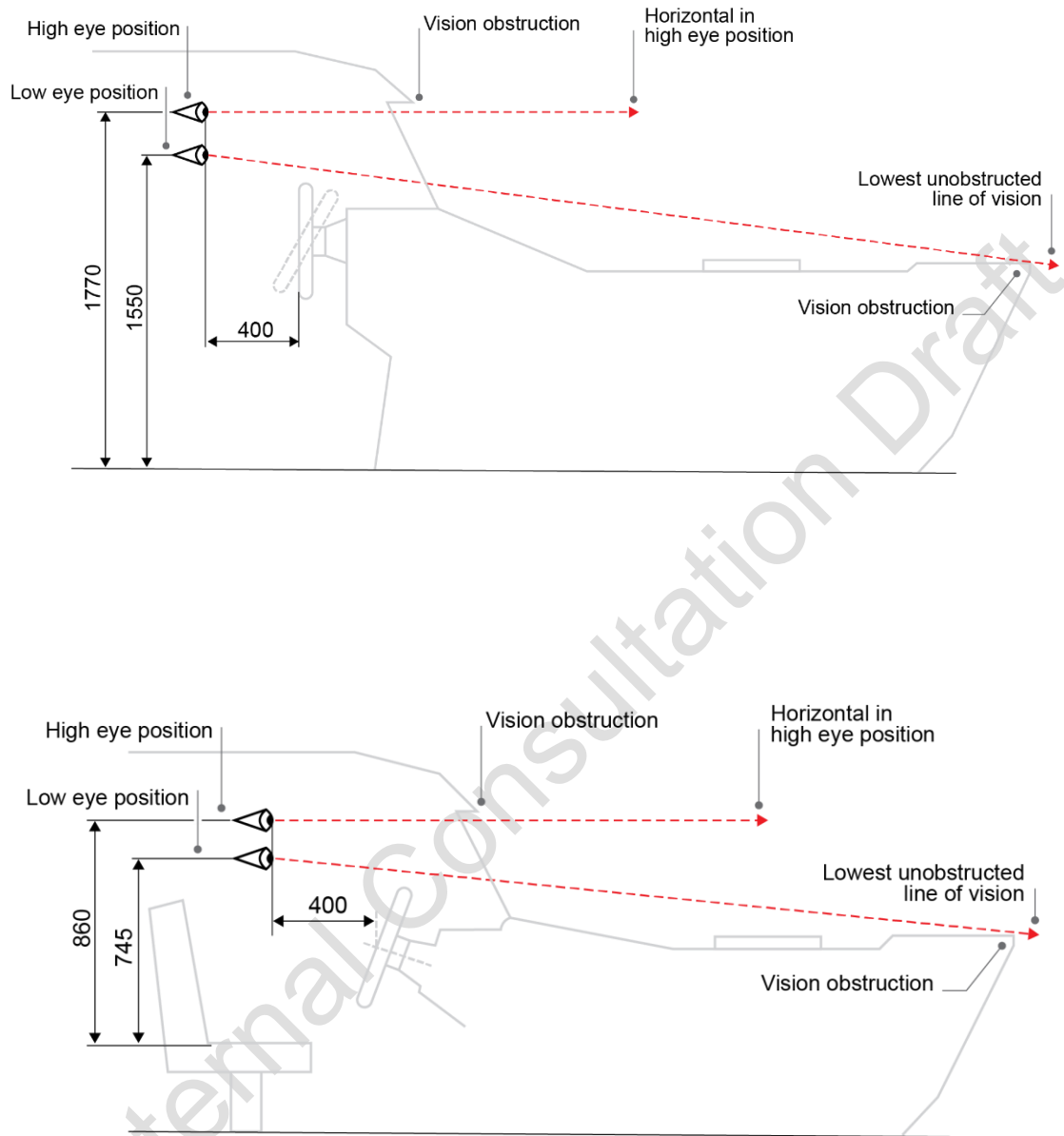

**Figure 2 — Field of vision for vessels  $\geq 24\text{m}$  from the operating station (clause 3.4)**

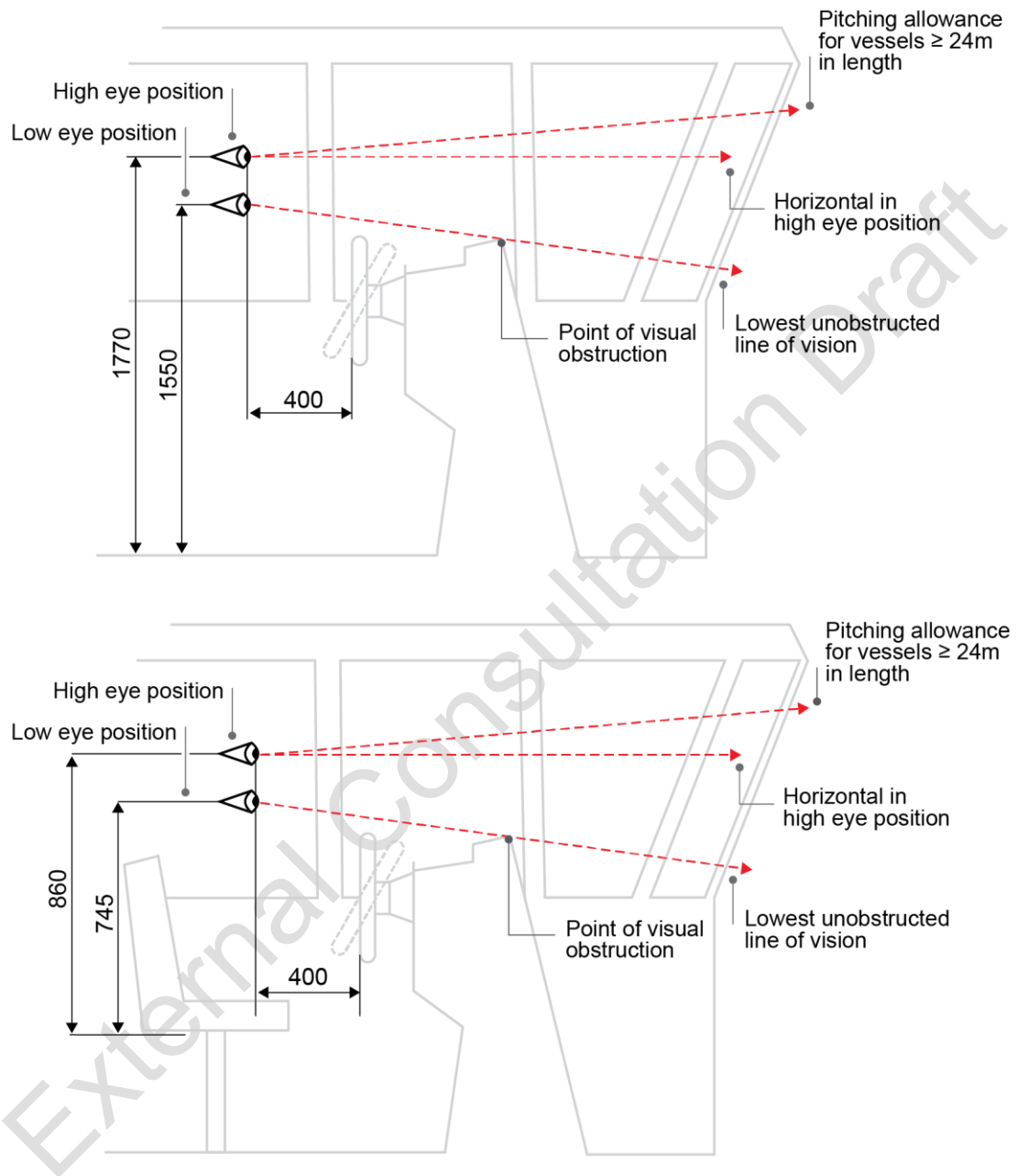

**Figure 3 — Field of vision from the operating station (clause 3.4)**

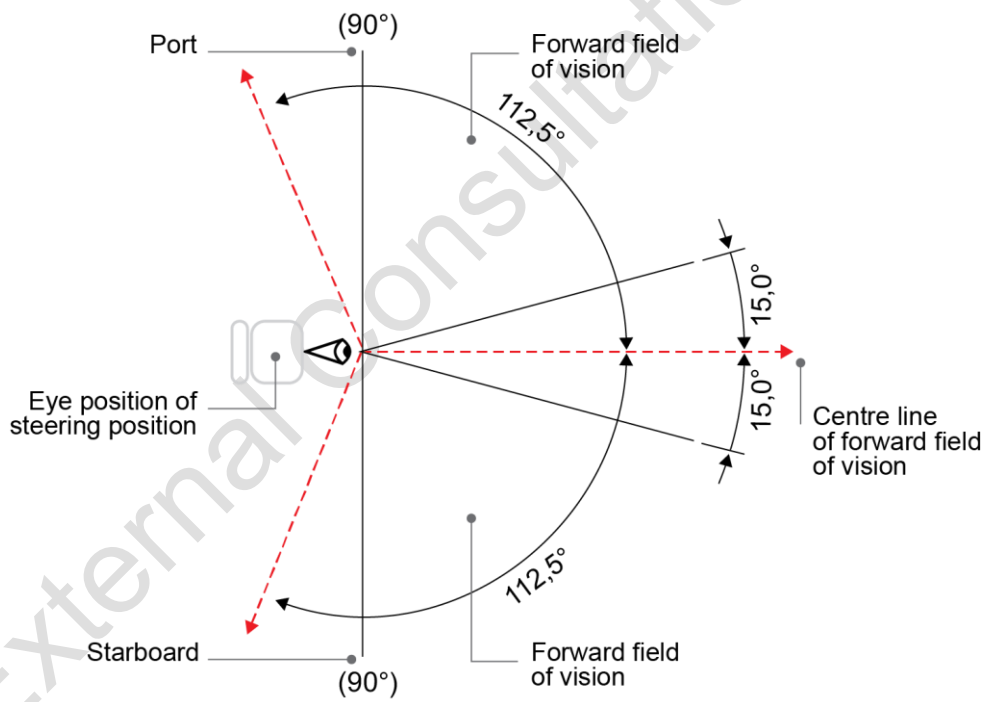
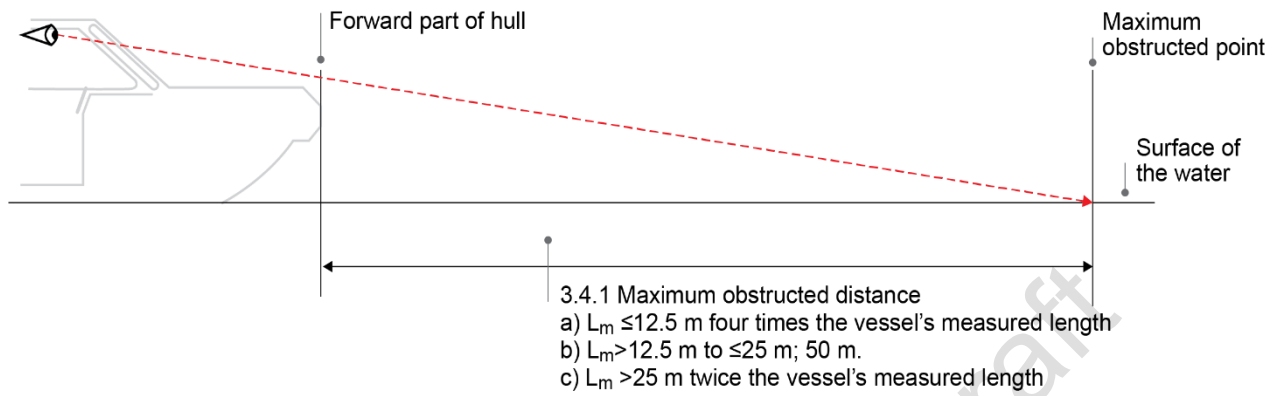



### 3.5 Glazing materials and tinting of windows used for navigation

- (1) Windows used for navigation must be glass or an equivalent material that has low levels of distortion and is resistant to scratching and crazing over time.
- (2) Glazing material used in a window that is used for the safe navigation of the vessel by a person at an operating station must have a light transmission of at least 70%, measured in accordance with AS/NZS 2080-2006 *Safety Glazing for Land Vehicles*.

NOTE Clause 3.5.16 limits the use of polarised and tinted windows in the operating compartment.

- (3) Any glazing materials used in a window mentioned in subsection (2) must not interfere with recognition of the colour of lights or other navigational markers seen through the material.
- (4) A window within the operating station may have a tinted blind of Mylar or similar material to reduce eye strain in bright sunshine that meets the following requirements:
  - (a) low optical distortion; and
  - (b) Anti glare reduction of 80% or more; and
  - (c) visible light transmission of at least 6.0% and:
  - (d) does not interfere with recognition of outside colours; and
  - (e) has a contained mechanism (chain or button) that allows the blind to be fully opened or fully closed.

NOTE It is recommended that blinds are Type Approved by a Recognised Organisation or comply with *ISO 8468 Ships and marine technology – Ship's bridge layout and associated equipment – Requirements and guidelines*.

### 3.6 Operating station layout, design and arrangement of navigational systems and equipment

- (1) The layout of the operating station must be designed to facilitate the following:
  - (a) maintaining a proper lookout from the operating station in accordance with COLREGS;
  - (b) use of controls for steering, propulsion and trim so that during use, operator hand contact can be maintained without movement of the operator's eye below the eye position for which the vessel is designed;
  - (c) the proper monitoring and use of equipment essential for command, navigation, manoeuvring without compromising the operator's obligations to operate the vessel in accordance with COLREGS; and
  - (d) the proper monitoring and use of communications equipment without interfering with the primary navigational functions in the operating station.
- (2) The operating station must be located and arranged to prevent or minimise distractions that might interfere with the vigilance of the operator.

- (3) The operating station must be located and arranged to prevent or minimise fatigue by avoiding any excessive or unnecessary effort required of the operator in fulfilling his or her duties.
- (4) Consoles and equipment within the operating station must:
  - (a) be designed and constructed to provide convenient and continuous access to information essential for controlling and monitoring the vessel and its safety, in full daylight and in darkness; and
  - (b) have information presented in a clear and unambiguous manner using standardised symbols and coding systems for controls and displays.
- (5) Indicators and controls in consoles must:
  - (a) be arranged to reduce the risk of adverse consequences arising from inadvertent error in use;
  - (b) be grouped to facilitate their correct operation; and
  - (c) be isolated from other controls if mistaken operation of the controls would cause a serious reduction in safety.
- (6) The operating station must be illuminated such that it is possible to discern displayed information and control devices in daylight and at night. In addition:
  - (a) the operating station must be arranged and equipped with sufficient control over lighting sources and lighting levels to allow the operator, during hours of darkness, to attain and maintain the levels of dark adaption that may be required to fulfil the operator's obligations under COLREGS; and
  - (b) care must be taken to avoid glare and stray image reflection in way of the operating station.
- (7) An operating station on a vessel may incorporate a seat that is arranged to be longitudinally or vertically adjustable.
- (8) On a vessel having more than 1 steering position, any steering position with propulsion and manoeuvring controls that are not in use must be able to be disengaged. However, sailing craft may be provided with multiple steering means some of which can't be disengaged and must be designed to allow safe and controller able transfer from one steering means to another.

## CHAPTER 4 ACCOMMODATION SPACES

### 4.1 Application

This Chapter applies to all vessels.

### DEEMED TO SATISFY SOLUTIONS

#### ACCOMMODATION, RECREATIONAL FACILITIES, FOOD AND CATERING

### 4.2 Accommodation level

All vessels must be assigned an accommodation level in accordance with Table 3.

Table 3 — Assigned accommodation levels

Level	Vessels
AL72+	All operational area category A, and B extended vessels; and operational Area B, C, D or E vessels with voyage durations greater than 72 hours without access to shore-based sleeping facilities
AL36-72	Operational Area B, C, D or E vessels with voyage durations greater than 36 hours and up to 72 hours without access to shore-based sleeping facilities
AL12-36	Operational Area B, C, D or E vessels on voyages without access to shore-based sleeping facilities for greater than 12 hours and up to 36 hours
AL<12	Operational Area B, C, D or E vessels on voyages without access to shore-based sleeping facilities of less than 12 hours

### 4.3 Requirements for accommodation spaces

- (1) The vessel must comply with the requirements mentioned in Table 4 that apply to the accommodation level assigned to the vessel.
- (2) For the purposes of this Chapter 4, requirements that apply to accommodation spaces for crew also apply to accommodation spaces for special personnel onboard the vessel.

**Table 4 — Application of requirements for accommodation spaces**

Clause	AL<12	AL12-36	AL36-72	AL72+
4.4 Headroom	Applies	Applies	Applies	Applies
4.5 Control of vermin and disease	Applies	Applies	Applies	Applies
4.6 Ventilation	Applies	Applies	Applies	Applies
4.7 Temperature control			Applies	Applies
4.8 Lighting	Applies	Applies	Applies	Applies
4.9 Noise and vibration	Applies	Applies	Applies	Applies
4.10 Requirements for crew and special personnel accommodation	Applies	Applies	Applies	Applies
4.11 Crew sleeping accommodation		Partially Applies	Applies	Applies**
4.12 Berths for crew		Applies	Applies	Applies**
4.13 Deck area for passengers	Passenger carrying vessels	Passenger carrying vessels	Passenger carrying vessels	Passenger carrying vessels
4.14 Seating accommodation for passengers	Passenger carrying vessels	Passenger carrying vessels	Passenger carrying vessels	Passenger carrying vessels
4.15 Sleeping accommodation for passengers			Applies	Applies
4.16 Access for persons with disabilities	Some Class 1	Some Class 1	Some Class 1	Some Class 1
4.17 Facilities for sick or injured persons				Applies
4.18 Recreational and mess facilities for crew and special personnel			Applies	Applies**
4.19 Galley and food storage facilities			Applies	Applies**
4.20 Sanitary facilities	Applies*	Applies*	Applies	Applies
4.21 Crew cloak and laundry facilities	Applies	Applies	Applies	Applies
4.22 Potable water	Applies*	Applies	Applies	Applies

\*There are exceptions for vessels on very short voyages, as set out in the provisions.

\*\*Some larger vessels are required to comply with the MLC – see Table 5.

#### 4.4 Headroom

- (1) An accommodation space on a vessel must have headroom of at least:
  - (a) for a vessel less than 24m in measured length – minimum of 1.9m;
  - (b) for a vessel of at least 24m but less than 35m in measured length – minimum of 1.98m; and
  - (c) for a vessel of at least 35m measured length – minimum of 2.03m.

**NOTE** Accommodation space is a defined term within NSCV Part B. To ensure vessels achieve the minimum headroom designers may need to consider things like lights, sensors and smoke detectors that can encroach on the minimum headroom.

- (2) Headroom in an accommodation space may be reduced on Class 2 and Class 3 in compartments that are not designed for permanent sustained occupation.

**EXAMPLE** Compartments not designed for permanent sustained occupation – heads or toilets on AL <12 vessels.

- (3) The clear height above the top of each stair that forms a stairway must be:
  - (a) For a vessel less than 35m measured length – minimum of 2m; and
  - (b) For a vessel at least 35m measured length – minimum 2.08m.

**NOTE** This additional clear height above stairs allows for people moving up or down and horizontally in a dynamic fashion.

#### 4.5 Control of vermin and disease

- (1) Materials used to construct internal bulkheads, deckheads, panelling and sheeting, and floors and joinings on a vessel must be chosen and installed so that the materials:
  - (a) facilitate and withstand periodic cleaning, washing down and drying; and
  - (b) prevent the harbouring of vermin and insects.
- (2) Accommodation spaces must be arranged to ensure that:
  - (a) excessive condensation on exposed internal bulkheads or deckheads is prevented; and
  - (b) decks subject to moisture in accommodation spaces have surfaces impervious to damp.

#### 4.6 Ventilation

- (1) All enclosed accommodation spaces must be ventilated at all times as follows:
  - (a) the system of ventilation must supply air free of engine exhaust and other contaminants;
  - (b) Mechanical ventilation of the capability specified must be provided to all accommodation spaces on the following vessels;

- i. Class 1 vessels – Capable of providing 10 changes of air per hour.
- ii. Class 2 and 3 vessels – Capable of providing 6 changes of air per hour; or

(c) Natural ventilation of the capability specified must be provided at all accommodations spaces on the following vessels;

- i. Class 1 vessels – at least 2 openable windows or similar apertures (one inlet and one outlet) where the total area of the two is required to be at least 5% of the compartment air volume in that particular space.
- ii. Class 2 and 3 vessels – at least 2 openable windows or similar apertures (one inlet and one outlet) where the total area of the two is required to be at least 4% of the compartment air volume in that particular space.

NOTE 1 Changes of air per hour is calculated when all access and other openings (other than ventilation intakes) to the spaces are closed.

NOTE 2 Open vessels or small vessels with a superstructure and opening windows may rely on natural ventilation only if the requirements of 4.6 and 4.7 can be satisfied.

- (d) all sanitary spaces shall have ventilation to the open air, independently of any other part of the accommodation; and
- (e) power for the operation of mechanical ventilation must be available at all times when the crew is living or working on board.

#### 4.7 Temperature control

- (1) Vessels assigned accommodation level AL72+ or AL36-72 must:
  - (a) be designed to ensure that a temperature range in crew accommodation spaces of between 14°C and 30°C is possible at least 95% of the time;
  - (b) have an active means of temperature control to provide heating and cooling in all accommodation spaces, except:
    - (i) if the vessel operates in a region with a 5th percentile annual mean minimum temperature of 14°C or more, in which case heating does not need to be provided; and
    - (ii) if the vessel operates in a region with a 95th percentile annual mean maximum temperature of 30°C or less, in which case cooling does not need to be provided;
- (2) The system of heating or cooling required under subsection 4.7(1)(b) must be operable at all times when persons are living or working on board.
- (3) For a vessel of at least 35 m measured length assigned accommodation level AL72+ or AL36-72 — the requirements of subsections 4.7(1) and 4.7(2) also apply to the operating station and any radio room and centralised machinery control room on the vessel.

NOTE Annual mean temperatures are available for land locations from the Bureau of Meteorology website.

#### 4.8 Lighting

A vessel must have the following:

- (a) lighting in all enclosed accommodation spaces, enabling:
  - (i) free movement around the accommodation space; and
  - (ii) a person to read; and
- (b) a means of blocking natural light to sleeping spaces.

#### 4.9 Noise and vibration

(1) Where there is the potential for exposure to noise that can contribute to hearing loss, spaces on a vessel must be arranged and equipped to comply with the following work health and safety requirements:

(a) for vessels, <1600 gross tonnage in operational area categories B, C, D and E – the *Code of Practice for managing noise and preventing hearing loss at work*, produced by Safe Work Australia;

- i. exposure durations greater than 8 hours must consider the effects of extended exposure.

NOTE 1 The *Code of Practice for managing noise and preventing hearing loss at work* includes provisions for: 1. Noise and its effects on health and safety; 2. The risk management process; 3. Assessing the risk; 4. Controlling the risk; and 5. The role of designers, manufacturers, importers, suppliers and installers of plan, substance or structure.

NOTE 2 As a guide, vessels over 50 m in length may exceed 1600 gross tonnage.

(b) for vessels  $\geq 1600$  gross tonnage or vessels of operational categories A or B extended – SOLAS Chapter II-1 Regulation 3-12 – Protection against noise.

NOTE SOLAS Regulation 3-12 calls up the *Code on noise levels on board ships* as adopted by the Maritime Safety Committee by resolution MSC.337(91).

#### 4.10 Requirements for crew and special personnel accommodation

Berthed accommodation spaces for crew and special personnel on a vessel must comply with the requirements mentioned in Table 5.

**Table 5 — Requirements for accommodation, recreational facilities, food and catering for crew and special personnel**

Vessel	Class of service:	
	1B Extended, 1B, 2A, 2B Extended, 2B	All other classes
Vessels that are <24m ≤AL12-36*	Clauses 4.11(2), (4)(b), (5), (6), (7), (8) and (9) and 4.12 of this Section, as applicable to the vessel.	
Vessels that are either:* - ≥24m to <35m; or - AL36-72	clauses 4.11, 4.12, 4.18 and 4.19 of this Section, as applicable to the vessel.	
Vessels that are either:* - ≥35 m; or - AL72+	Must comply with MLC 2006 regulation 3.1 (accommodation and recreational facilities). See note 2.	clauses 4.11, 4.12, 4.18 and 4.19 of this Section, as applicable to the vessel.

\* If a vessel fits in multiple categories, the vessel is subject to the highest category it fits within. For example, a vessel that is <35m but AL72+, is subject to the requirements for vessels AL72+.

NOTE 1 A vessels GT can be confirmed from the shipping register.

NOTE 2 The owner and or operator may have responsibilities around the supply of food and catering, regulation 3.2 of MLC 2006.

#### 4.11 Crew sleeping arrangements

- (1) Clauses (2), (4)(b), (5), (6), (7), (8) and (9) applies to all vessels. Clauses (3) and (4)(a) apply only to vessels assigned accommodation level AL36-72 or AL72+, that are not subject to the MLC 2006.
- (2) Crew sleeping arrangements on a vessel operating at sea must be located to minimise the effects of motion and acceleration.
- (3) Crew sleeping arrangements must be separate from cargo and storage spaces.
- (4) Crew sleeping arrangements must be separated from other spaces on the vessel to prevent or minimise the following:
  - (a) movement of persons to other spaces via the crew sleeping arrangements;
  - (b) liquids, odours and fumes entering into the crew sleeping arrangements from other spaces.
- (5) Noise in sleeping accommodation must not exceed the sound levels specified in Table 6.



**Table 6 – Cabin noise levels to assist in rest and fatigue prevention**

<b>Accommodation Level</b>	<b>Accommodation space</b>	<b>dB(A)</b>
AL36-72 and AL72+	Crew sleeping arrangements and berthed spaces	≤65 at normal service speed.

- (6) Bulkheads separating crew sleeping arrangements from cargo holds, fish rooms and machinery spaces must be watertight and gastight.
- (7) Except for emergency escape, there must be no direct openings into crew sleeping arrangements from:
- (a) cargo holds, fish rooms or machinery spaces; and
  - (b) on a vessel of at least 35 m measured length :
    - (i) galleys;
    - (ii) storerooms; and
    - (iii) drying rooms.
- (8) Crew sleeping arrangements on a vessel must have the following measures:
- (a) the maximum number of crew per crew sleeping arrangements must not exceed the number mentioned in Table 7 for the accommodation level and measured length ( $L_m$ ) of the vessel;
  - (b) on a vessel assigned accommodation level AL72+, officers must be accommodated in sleeping rooms that are separate from the crew;
  - (c) Crew sleeping arrangements must be arranged to provide appropriate levels of privacy for men and for women; and
  - (d) the maximum number of crew to be accommodated in any crew sleeping arrangement must be legibly and indelibly marked on the exterior and interior of the crew sleeping arrangement door.
- (9) The floor area inside a crew sleeping arrangement must:
- (a) have adequate space and comfort for the crew occupying the room; and
  - (b) have a minimum floor area per person, excluding space occupied by berths and lockers, of at least that mentioned in Table 7 for the accommodation level and measured length ( $L_m$ ) of the vessel.

**Table 7 — Minimum floor area and maximum number of crew in crew sleeping arrangements**

Accommodation level	Maximum number of crew per sleeping room	Minimum required clear deck area per person (m <sup>2</sup> )			
		L <sub>m</sub> ≥ 35 m	L <sub>m</sub> < 35 m to 24 m	L <sub>m</sub> < 24 m	All
		Sleeping room	Sleeping room	Sleeping room	Total, including communal areas for recreational use, excluding passageways
AL72+	4	2.0	0.9	0.9	2.0
AL36-72	6	1.5	0.7	0.5	1.5

#### 4.12 Berths for crew

- (1) The vessel must have the following for each member of the crew:
  - (a) a separate berth; and
  - (b) a mattress.
- (2) Berths must be located so that a person can reach a berth without disturbing a person occupying another berth.
- (3) The material and construction of a berth and mattress must be resistant to vermin infestation and facilitate restful sleep.
- (4) The minimum inside dimensions of the berths must be at least those mentioned in Table 8.

**Table 8 — Minimum dimensions of sleeping berths**

Minimum berth dimensions inside length (mm) x breadth (mm)		
Vessel kind	Length of berth (mm)	Breadth of berth (mm)
AL12 - 36* vessels	1900	700
AL 36-72 and AL 72+ vessels	1980	800

\*A vessels AL<12 is not required to comply with Table 8.

- (5) Berths may be arranged in tiers if:
  - (a) the minimum clear height between decks is at least 1900 mm; and
  - (b) a tier has no more than 2 berths; and
  - (c) the underside of the mattress of the lower berth is at least 300 mm above the deck; and
  - (d) the clear space between the topside of the mattress of the lower berth and the underside of the top berth is at least 635 mm; and

- (e) the upper berth is placed approximately midway between the bottom of the lower berth and the lower side of the deckhead beams; and
  - (f) the upper berth has a barrier preventing dust from dropping onto the lower berth.
- (6) A sleeping room must have the following:
- (a) separate locker space for each person for clothing and other personal effects;
  - (b) for a vessel assigned accommodation level AL72+ — the locker space for each person must have:
    - (i) a suitable locking device; and
    - (ii) a rod for holding clothes on hangers; and
    - (iii) a drawer or equivalent space that is at least 0.06 m<sup>3</sup>;
  - (c) a suitable writing surface on a vessel assigned accommodation level AL72+; and
  - (d) for a vessel more than 35 m measured length assigned accommodation level AL72+ — a writing surface that is a desk, and a chair.

#### PASSENGER SPACES

##### **4.13 Deck area for passengers**

- (1) The maximum number of passengers allowed access to a deck is the least number determined in accordance with the following criteria:
- (a) intact stability in NSCV Part C Subsection 6A;
  - (b) buoyancy and stability after flooding in NSCV Part C Subsection 6B;
  - (c) minimum clear deck area in Table 9;
  - (d) minimum seating in Table 10; and
  - (e) escape or evacuation mentioned in Chapter 6.

NOTE The total number of passengers may also be limited by the quantity of life-saving equipment fitted to the vessel - see NSCV Part C Subsection 7A.

- (2) Each deck on a passenger-carrying vessel must have a minimum clear deck area per passenger of at least that mentioned in Table 9.

**Table 9 — Minimum required clear deck area per passenger**

Class of vessel	Minimum clear deck area in m <sup>2</sup> /passenger	
	Passage time >2 hours	Passage time ≤2 hours
A, B Extended, B	0.85	N/A
C	0.81	0.55
D	0.55	0.55
E	0.55	0.40

- (3) For determining the available clear deck area:
- (a) a seated person must not be deducted from the number of persons used in the calculation; and
  - (b) an area for seating must not be deducted from the available area if:
    - (i) the seat allocated to a single person is not of excessive size; and
    - (ii) the number of seats provided does not exceed the number of persons intended to use the space; and
  - (c) if fixed seating is fitted at the perimeter of the space, the measurements must be taken from the front surface of the back of the seat; and
  - (d) if the area of an individual seat, including 300 mm leg room, exceeds the required area per person mentioned in Table 9 the area exceeding must be deducted from the available clear deck area.

#### **4.14 Seating accommodation for passengers**

- (1) A vessel must have seating accommodation as follows:
- (a) for a vessel in operational area A, Extended B or B — seating provision must be made for each passenger; and
  - (b) for a vessel in operational area C, D or E — the seating mentioned in Table 10 is required.

**Table 10 — Minimum required seating accommodation for passengers on vessels in operational areas C, D and E**

Anticipated time on board	Minimum seating as a proportion of total number of passengers (%)		
	Operational area C	Operational area D	Operational area E
≥60 minutes	100%	100%	100%
≥30 and <60 minutes	100%	100%	75%
≥15 and < 30 minutes	100%	75%	40%
<15 minutes	75%	40%	40%

- (2) Seating for passengers on a vessel:
- (a) must be located in a position:
    - (i) protected from the force of the sea; and
    - (ii) where the likelihood of falling overboard or injury is minimal; and
  - (b) where a seat does not have an adequate backrest or support, adequate hand holds must be provided and seating or obstructions in the “no climb zone” must not reduce the height and performance of person overboard preventions mentioned in clause 6.4.

**EXAMPLE OF OBSTRUCTIONS** Pipes, hatches etc.

**NOTE** Seating may be placed in the no climb zone with increased guardrail height to ensure the performance requirements of 6.4 are maintained.

**Figure 4 – No climb zone**

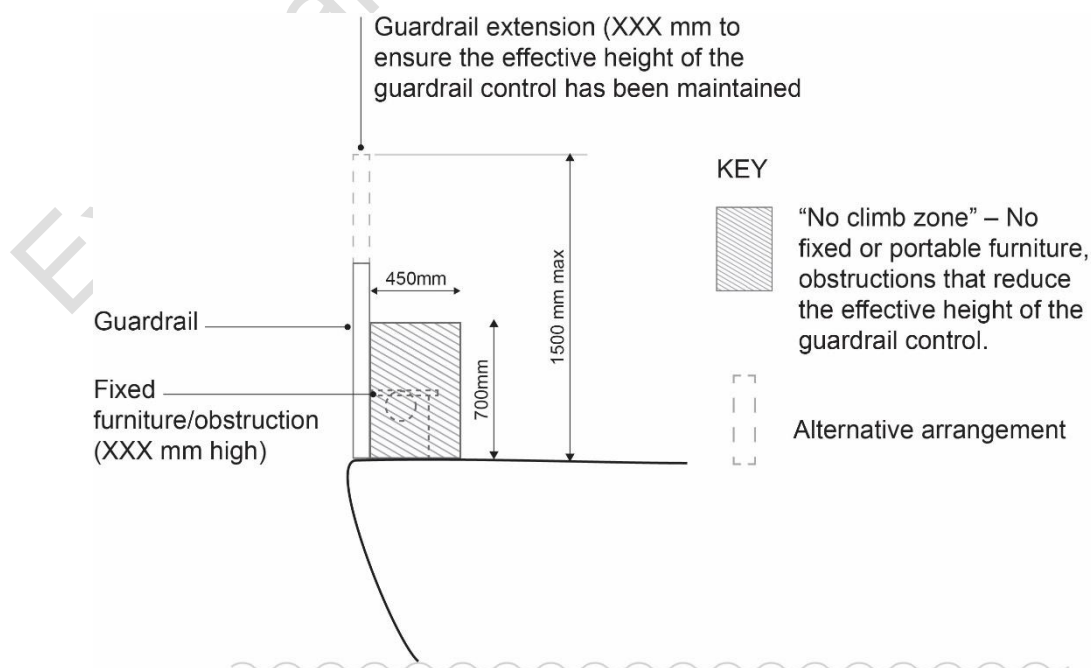

- (c) unless subsection (4) applies — must not be placed along the collar of a collared vessel; and
  - (d) if continuous seating is provided — must consist of at least 475 mm of seating for each person; and
  - (e) All seating and furniture must normally be fixed. Any moveable furniture may only be permitted provided this would not be a hazard or impede escape in the event of an emergency.
- EXAMPLE** Hazard might be portable deck furniture encroaching on an escape or evacuation path.
- (f) However, when portable seating is used in sheltered waters it must have a safe working limit of 200kg per seat.
- (3) A vessel must have the following seating arrangements:
- (a) for seats arranged in rows facing one way — the distance from seat front to seat front must be at least 750 mm;
  - (b) aisles forming passageways between banks of fixed seating must at least the widths mentioned in Table 11;
  - (c) the clearance between rows of fixed seats measured horizontally from the squab of the seat must be at least:
    - (i) 300 mm if the distance from a seat to an aisle is 3.5 m or less; or
    - (ii) 500 mm if the distance from a seat to an aisle is more than 3.5 m.

**Table 11 — Aisles forming passageways between banks of fixed seating**

Number of persons served	Minimum width of aisle (mm) For aisle length	
	≤4.5 m	>4.5 m
Up to 18	See clause 5.11	See clause 5.11
18 to 72	600	750
More than 72	750	750

- (4) For a collared vessel carrying divers and operating at speeds up to 25 knots, inclusion of sections of the collar as seating is deemed-to-satisfy if the seating on the collar complies with the following:
- (a) the upper surface of the collar in the way of the seat is at least 400 mm above the cockpit deck;
  - (b) the surface of the collar has a slip-resistant surface at the point where each diver is seated with at least 700 mm of collar length for each diver;
  - (c) each diver is provided with at least 2 points of attachment to the vessel;

- (d) the points of attachment are arranged to ensure that holding on to the attachments prevents the diver from falling overboard;
- (e) only 1 point of attachment is fixed directly to the collar itself.

EXAMPLE See figure 5 for an illustration of the requirements of (4)(a) to (e).

**Figure 5 — Example of collared vessel seating and points of attachment**

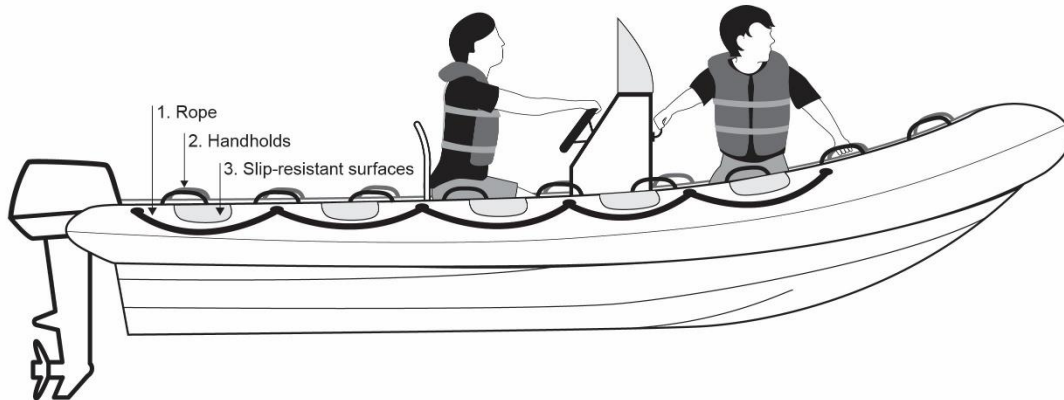

NOTE NSCV Part C Subsection 6A also specifies requirements for seating on collared vessels.

#### **4.15 Sleeping accommodation for passengers**

- (1) This clause applies to a vessel assigned accommodation level, AL36-72 or AL72+ that accommodates passengers.
- (2) Sleeping accommodation for passengers must be separate from crew sleeping places and each person supplied a berth.
- (3) Sleeping areas for passengers must be safe and hygienic for the intended passenger.

EXAMPLE Vessels required to provide access or intended to cater for people with disabilities need to consider the design of sleeping areas and access are appropriate.

#### ACCESS FOR PERSONS WITH DISABILITIES

#### **4.16 Vessels considered public transport must be accessible to persons with disabilities**

Public transport operators have an obligation under the *Disability Discrimination Act 1992 (Cth)* public transport standards to provide an accessible environment for passengers with disabilities to conveyances, including ferries.

NOTE 1 The transport standards are known as the *Disability Standards for Accessible Public Transport 2002*. The *Disability Standards for Accessible Public Transport Guidelines 2004* provide additional guidelines.

NOTE 2 Additional guidance is provided by – *Guidelines: Equivalent Access under the Disability Standards for Accessible Public Transport 2002 (Cth)* that designer may need to be aware of at the design stage.

NOTE 3 AS 1428.1:2021 Design for access and mobility, Part 1: General requirements for access - New building work, maybe applicable.

## MEDICAL CARE ON BOARD VESSELS

### **4.17 Facilities for sick or injured persons**

A vessel must have the following measures for sick or injured persons:

- (a) for a vessel assigned accommodation level AL72+ - at least 1 shared cabin with a space designated for use as a sick bay to separate a sick or injured person from other persons on board;
- (b) for a vessel of operational area A or B Extended, and more than 35 m measured length - a designated sick bay arranged and equipped specifically for the purpose.

## MESS AND RECREATIONAL FACILITIES

### **4.18 Recreational and mess facilities for crew and special personnel**

- (1) A vessel assigned accommodation level AL36-72 or AL72+, that is not required to comply with the MLC 2006, must have a mess facility for crew that is:
  - (a) equipped with tables and seats to accommodate at least two thirds of the crew in any one sitting; and
  - (b) located close to the galley; and
  - (c) if the vessel is assigned accommodation level AL72+ or there are more than 10 crew - separate from sleeping quarters.
  - (d) In addition to the mess facility a vessel assigned accommodation level AL72+ must have recreational facilities or amenities provided to all crew.
- (2) A vessel required to fit heating, cooling or both under clause 4.7 must have the following facilities in the mess room that are available and accessible to crew and special personnel at all times:
  - (a) if heating is required - facilities for making hot drinks; and
  - (b) if cooling is required - a refrigerator of sufficient capacity or another means of supplying chilled drinks.

## GALLEY AND FOOD STORAGE

### **4.19 Galley and food storage facilities**

- (1) This clause applies to a vessel assigned accommodation level AL36-72 or AL72+, that is not subject to the MLC 2006.
- (2) A vessel must have cooking areas as follows:
  - (a) for a vessel assigned accommodation level AL72+ or AL36-72 - facilities for preparing and cooking food;



- (b) if a separate galley is not provided, the galley, or cooking area must be of adequate size for the purpose - well lit and ventilated and surfaces must be suited to convenient and effective cleaning.
- (3) A vessel must have the following, sufficient for crew and passengers for the duration of the voyage:
  - (a) a suitable place for provisions that can be kept dry, cool and well ventilated to avoid deterioration of the stores;
  - (b) a refrigerator or other low temperature storage;
  - (c) for a vessel assigned accommodation level AL72+ - a dedicated provisions storeroom and cool-room.
- (4) Waste must be:
  - (a) isolated; and
  - (b) kept in closed, well-sealed containers that are intended to be removed from foodhandling areas at regular intervals.

**SANITARY ARRANGEMENTS**

**4.20 Sanitary facilities**

A vessel must have toilets, washbasins and showers or baths for the use of all persons on board:

- (a) in accordance with Table 12; and
- (b) if required by Table 13, the number mentioned in Table 14.

**Table 12 — Requirements for fitting of toilets and wash basins on vessels**

<b>Vessel use category</b>	<b>Number of passengers</b>	<b>Threshold passage time before toilet facilities and washbasins required</b>
Class 1	≥201	15 minutes.
	37 to 200	15 minutes.  However, for vessels not considered public transport, toilets and washbasins are not required if the vessel is engaged on voyages of less than 30 minutes duration where the vessel operates between dedicated ferry terminals, wharves or a parent vessel with adequate public sanitary facilities provided.
	13 to 36	30 minutes.  However, for vessels not considered public transport, toilets and washbasins are not required if the vessel is engaged on voyages of less than 45 minutes duration where the vessel operates between dedicated ferry terminals or wharves or a parent vessel with adequate public sanitary facilities provided.
Class 2	1 to 12	2 hours

Vessel use category	Number of passengers	Threshold passage time before toilet facilities and washbasins required
	0	12 hours
Class 3	0	12 hours

**Table 13 — Minimum required number of toilets, washbasins and showers or baths on vessels**

Type of accommodation	Toilets	Washbasins	Showers or baths
Unberthed: Voyage time 1 hour or more and 100 persons or less	1 for every 50 persons or fewer  Example - 1 toilet is needed for 1 to 50 persons; 2 toilets are needed for 51 to 100 persons and so on.	1 for up to and including 50 persons	Not required
Unberthed: Voyage time 1 hour or more and more than 100 persons	For 101 to 200 persons - 3 For each additional 100 persons or part thereof - 1 more  Example - 4 toilets would be required on a vessel which can carry between 201 and 300 persons	For 101 to 200 persons - 3 For each additional 200 persons or part thereof - 1 more  Example - 4 washbasins would be required on a vessel which can carry between 201 and 400 persons	Not required
Unberthed: Voyage time less than 1 hour and 150 persons or less	1	1	Not required
Unberthed: Voyage time less than 1 hour and more than 150 persons	For 151 to 300 persons - 2 For each additional 150 persons or part thereof - 1 more  Example - 3 toilets would be required on a vessel which can carry between 301 and 450 persons	For 151 to 300 persons - 2 For each additional 200 persons or part thereof - 1 more  Example - 3 washbasins would be required on a vessel which can carry between 301 and 500 persons	Not required

Type of accommodation	Toilets	Washbasins	Showers or baths
Berthed AL72+	1 for every 6 persons or fewer	1 for every 6 persons or fewer	1 for every 6 persons or fewer
Berthed AL36-72	1 for every 8 persons or fewer	1 for every 6 persons or fewer	1 for every 8 persons or fewer
Berthed AL12-36	1 for every 15 persons or fewer	1 for every 15 persons or fewer	Not required

- (2) Sanitary facilities must have the following hygiene measures:
- (a) for berthed persons - fresh water, both hot and cold, at each washbasin, shower and bath;
  - (b) for unberthed persons - cold freshwater at each washbasin;
  - (c) toilets with ample flush of water, available at all times and independently controllable;
  - (d) hygeine bins situated in toilet facilities for disposal of female sanitary products;
  - (e) sanitary facilities and the spaces containing them arranged to prevent contamination of other spaces;
  - (f) all surfaces in sanitary spaces to facilitate easy and effective cleaning;
  - (g) floors with a slip-resistant deck covering;
  - (h) sanitary facilities fitted with ventilation; and
  - (i) ventilation to the outside, independent of any other part of the accommodation.
- (3) Sanitary facilities must have privacy.

#### 4.21 Crew cloak and laundry facilities

A vessel must have the following measures for crew cloak and laundry facilities:

- (a) a place for the crew to hang foul-weather gear and other personal protective equipment outside, but convenient to, sleeping rooms or crew mess;
- (b) for a vessel assigned accommodation level AL72+ - adequate facilities for the crew to wash, dry and iron clothes;
- (c) if the vessel is at least 35 m measured length and assigned accommodation level AL 72+:

- (i) facilities for washing, drying and ironing clothes in a compartment separate from sleeping rooms, mess rooms and toilets;
- (ii) adequate ventilation and heating, and lines or other means of drying clothes.

**POTABLE WATER ARRANGEMENTS**

**4.22 Potable water**

- (1) A vessel must have, for drinking and hygiene purposes:
  - (a) in each wash place:
    - (i) cold potable water; and
    - (ii) either hot potable water or a means of heating water on vessel with an accommodation level higher than 12 hours; and
  - (b) for the normal duration of a voyage - at least the amount of potable water mentioned in Table 14.

**Table 14 — Minimum amount of potable water**

Assigned accommodation level	Minimum amount of potable water per person per day or part day
AL72+	60 Litres
AL36-72	60 Litres
AL12-36	20 Litres
AL<12	5 Litres (on short voyages ≤2 hours, this may be reduced to 2 litres per person) No potable water is required to be carried for vessels AL<12 on short voyages of less than 1 hour where a toilet, washbasin or shower is not required to be fitted under Table 12

**NOTE** Small vessels with an AL<12 may have carry on water in appropriate containers or bottles that satisfy the potable water requirements when wash basin facilities are not required.

- (2) A vessel fitted with potable water tanks must comply with the following requirements:
  - (a) tanks for potable water must have no common boundary with other tanks on board containing liquids, if contamination by those liquids could have serious health consequences for persons on board;
  - (b) tanks for potable water must be labelled “Potable Water”; and
  - (c) to facilitate periodic inspection and cleaning, tanks for potable water must be accessible through a watertight manhole or, if sufficient, a watertight hand hole, and must be completely drainable from a bottom drain; and

(d) tanks for potable water are to be lined internally with a corrosion control coating suitable for the containment and transfer of fresh water.

NOTE Suitable standards that the designer and owner should be aware of are:

- *AS4020:2018 Testing of products for use in contact with drinking water - AS/NZS 4020* is a standard that is designed to test any products for use in contact with drinking water, lining and coatings of potable water tanks is one example.
- *ISO 15748-1 Ships and marine technology – Potable water supply on ships and marine structures: Planning and design*
- WHO – International health regulations - *Guide to Ship Sanitation*.
- *Australian Drinking Water Guidelines – ADWG*. Importantly it describes various disinfection approaches and properties depending on the quality of source water, which can be variable for vessels. It also provides information on disinfection, sampling, statistics, and fact sheets.

External Consultation Draft

## CHAPTER 5 ESCAPES AND EVACUATION

### 5.1 Application

This Chapter applies to all vessels.

### DEEMED TO SATISFY SOLUTIONS

#### ESCAPES

### 5.2 General escape requirements

- (1) Means must be provided for all persons onboard to be able to escape and access an evacuation path from any space which may be occupied under normal operational circumstances readily in an emergency or hazardous situation, assuming that all persons are wearing a lifejacket of the type required to be provided on the vessel.
- (2) Means of escape must be provided from all crew, special personnel and passenger spaces:
  - (a) in the form of doorways, stairways, ladder ways or, in enclosed spaces, emergency windows or appropriate sliding doors, in accordance with the requirements of this chapter;
  - (b) in enclosed areas or spaces, there must be both a primary means of escape and an alternative means of escape, unless the space complies with Table 15. The alternative means of escape must be in a location widely separated from the primary means of escape;
  - (c) the capacity of the primary means of escape and, where required, the alternative means of escape must be in accordance with clause 5.4; and
  - (d) all escapes must be clearly marked, and escape lighting must be provided for some higher risk vessels as required by clause 5.16 and Table 26.

NOTE Table 15 provides conditions and controls for a limited number of spaces to have a single means of escape.

### 5.3 Escape from spaces

- (1) Spaces normally occupied below the bulkhead deck must have at least 1 means of escape that does not rely on passage through a watertight bulkhead.
- (2) An escape from a high fire risk space must not be through another high fire risk space.
- (3) Control spaces on a vessel must comply with the following requirements for escape routes:
  - (a) an enclosed control space occupied for extended periods during an emergency (eg the operating compartment, machinery control rooms

or compartments containing emergency steering gear) must have an alternative means of escape, unless configured in accordance with Table 15;

- (b) at least 1 of the means of escape must be to a space different from that accessed by other escapes from the control space.
- (4) A vessel with a ro-ro space must have the following:
  - (a) at least 2 means of escape from each end of the ro-ro space:
    - (i) 2 means of escape at the fore end; and
    - (ii) 2 means of escape at the aft end; and
  - (b) escape routes with safe access to an evacuation path.
- (5) If passengers have access to ro-ro spaces, escapes additional to those mentioned in subsection (5) must be provided so that the distance from any point within the ro-ro space to an escape does not exceed 30 metres.
- (6) A dead-end corridor must be arranged and marked to deter a person from entering the corridor in an emergency.

**Table 15 — Spaces not required to have an alternative means of escape**

Type of space	Conditions
Accommodation space	All of the following apply: <ul style="list-style-type: none"> <li>(a) the space does not accommodate more than 6 passengers or more than 8 persons in total;</li> <li>(b) the single means of escape is not through a watertight door;</li> <li>(c) the maximum actual horizontal travel distance to the point of escape does not exceed 5 m for passenger accommodation or 7 m for accommodation for crew only;</li> <li>(d) the single means of escape does not lead to a space that does not itself have direct access to open decks;</li> <li>(e) the space is not also of moderate fire risk (containing a small galley or a moderate fire risk machinery space);</li> <li>(f) the single means of escape does not lead to a space classified as high fire risk or moderate fire risk.</li> </ul>
High fire risk machinery space arranged for unmanned operation, dedicated moderate fire risk machinery space or galley	All of the following apply: <ul style="list-style-type: none"> <li>(a) the maximum actual horizontal travel distance to the point of escape does not exceed 5 m;</li> <li>(b) the single means of escape is not through a watertight door;</li> <li>(c) the single means of escape does not lead to a space that does not itself have direct access to open decks;</li> </ul>

Type of space	Conditions
	(d) the single means of escape does not lead to a space classified as high fire risk or moderate fire risk
Space of low fire risk	All of the following apply: (a) it is only entered by crew; (b) it is only occupied occasionally

#### 5.4 Design of escapes serving a space

(1) The design of an escape must:

- (a) take into account the number of persons who may need to use it; and
- (b) take into account whether it is to be used by passengers or by crew;
- (c) for escapes in the form of doors or windows – the doors or windows must be capable of being opened from either side; and
- (d) comply with the requirements of this clause 5.4.

NOTE The number of persons who may need to use the escape must take into account the number of persons who may need to use the evacuation path that the escape forms part of.

(2) The access and escapes for each space are either low-capacity or high-capacity, as set out in Table 16 and Table 17.

(3) A high-capacity escape must comply with Table 18.

(4) A low-capacity escape must comply with Table 19.

(5) The following are not means of escape:

- (a) a lift; and
- (b) unless it has a viable evacuation path to the survival craft embarkation deck or an assembly area - the following spaces:
  - (i) an accessway;
  - (ii) a balcony; and
  - (iii) open decks.



**Table 16 — Types of escapes from accommodation spaces**

<p><b>Nominal number of persons within the space</b></p> <p>The nominal number of persons in the space is:</p> <ul style="list-style-type: none"> <li>- for Class 1: the sum of the number of passengers and 2/3 number of crew; and</li> <li>- for Class 2 and 3: the sum of the number of passengers and the number of crew.</li> </ul>	<p><b>Primary access</b></p>	<p><b>Alternative escapes</b></p>
<p>0 to 4</p>	<p>Low-capacity acceptable, rung ladders limited to use by crew only and not more than <b>2.2 m high</b></p>	<p>Low-capacity acceptable</p>
<p><b>0 to 4</b></p>	<p><b>Low capacity acceptable, ladders limited to between 60 and 75 degrees with handrails either side and not more than 2.2 m high</b></p>	<p><b>Low-capacity acceptable</b></p>
<p>5 to 12</p>	<p>Low-capacity door, stairway, passageway or walkway acceptable (but not rung ladder), step ladders limited to not more than <b>2.2 m high</b></p>	<p>Low-capacity acceptable</p>
<p>13 to 72</p>	<p>High-capacity</p>	<p>Single high-capacity, or low-capacity counted at 18 persons each</p>
<p>&gt;72</p>	<p>High-capacity*</p>	<p>High-capacity and up to 4 low-capacity counted at 18 persons each</p>

\* For spaces with a nominal number of >72 persons, high-capacity escapes may require multiple primary high-capacity escapes. For example, using 900mm escapes, for 100 passengers: two primary high-capacity, one high-capacity and two low-capacity escapes will be required.

**Table 17 – Types of escapes from workspaces**

Number of crew normally in the space	Primary access	Alternative escapes
0 to 4	Low-capacity acceptable, rung ladders limited to not more than 6 m high	Low-capacity acceptable Rung ladders limited to not more than 6 m high
5 to 12	Low-capacity door, stairway, passageway or walkway acceptable	Low-capacity acceptable Rung ladders limited to not more than 6 m high
≥13	High-capacity	High-capacity; or low-capacity counted at 18 persons each

**Table 18 — Minimum criteria for high-capacity escapes**

Type of space	Passenger spaces	Crew spaces
Corridor or passageway	Sized in accordance with Annex A with a minimum width of: <ul style="list-style-type: none"> <li>- if the vessel carries &gt;36 pax – 900 mm; and</li> <li>- all other vessels – 700 mm</li> </ul>	Sized in accordance with Annex A with a minimum width of 700 mm
Doorway	Sized in accordance with Annex A with a minimum width of: <ul style="list-style-type: none"> <li>- if the vessel carries &gt;36 pax – 900 mm; and</li> <li>- all other vessels – 700 mm</li> </ul>	Sized in accordance with Annex A with a minimum width of 700 mm
Stairway	Sized in accordance with Annex A with a minimum width of: <ul style="list-style-type: none"> <li>- if the vessel carries &gt;36 pax – 900 mm; and</li> <li>- all other vessels – 700 mm</li> </ul> Treads in accordance with clause 5.14(4) Slope in accordance with clause 5.13(2) Width of hatches associated with stairways in accordance with Annex A	Sized in accordance with Annex A with a minimum width of 700 mm Treads in accordance with clause 5.14(4) Slope in accordance with clause 5.13(2) Width of hatches associated with stairways in accordance with Annex A

Type of space	Passenger spaces	Crew spaces
Ladder	Not considered a high-capacity escape	Not considered a high-capacity escape
Escape hatch	Not considered a high-capacity escape	Not considered a high-capacity escape
Walkway	<p>Sized in accordance with Annex A with a minimum width of:</p> <ul style="list-style-type: none"> <li>- if the vessel carries &gt;36 pax - 900 mm; and</li> <li>- all other vessels - 700 mm</li> </ul> <p>Slope - see preferred slope in clause 5.13(2)</p>	<p>Sized in accordance with Annex A with a minimum width of 700 mm</p> <p>Slope — see clause 5.13(2)</p>

**Table 19 — Minimum criteria for low-capacity escapes**

Type of space or element	Passenger spaces	Crew spaces
Corridor	Minimum clear width 650 mm	Minimum clear width 600 mm
Passageway	Minimum width - see <b>Table 22</b>	Minimum width - see <b>Table 22</b>
<p>Doorway, vertical escape hatch, pop-out window,</p> <p><b>NOTE: A doorway includes a hinged and sliding doors.</b></p>	<p>Minimum dimensions in accordance with <b>Table 21</b>.</p> <p><b>Pop-out windows installed in a weathertight envelope must be weathertight. All pop-out windows must be openable within 60 seconds with clear instructions visible and must not exceed 700mm of the deck from the lower edge of the window.</b></p>	<p>Minimum dimensions in accordance with <b>Table 21</b></p>
Emergency window (break glass)	<p>Minimum dimensions in accordance with Table 21. Not be designed as the primary escape.</p> <p><b>A maximum height off the deck of 700mm from the lower edge of the window.</b></p> <p><b>Emergency windows must be of a break glass standard with appropriate tempering that has an escape hammer that is appropriate to break the thickness and strength of the glass in the case of an emergency. The escape hammer must be clearly marked and secured within 1m of the emergency window.</b></p>	

Type of space or element	Passenger spaces	Crew spaces
Stairway	Minimum clear width 650 mm Treads in accordance with clause 5.14 Slope in accordance with clause 5.13(2)	Minimum clear width 600 mm Treads in accordance with clause 5.14 Slope in accordance with clause 5.13(2)
Ladder	Step ladders of height greater than 2.2 m applicable only if direction of flow is upward. Minimum width clause 5.15(1) Treads in accordance with clause 5.15(1) Slope in accordance with clause 5.13(2)	Minimum width clause 5.15(1) Treads in accordance with clause 5.15(1) Slope in accordance with clause 5.13(2)
Horizontal escape hatch	Minimum 460 mm x 460 mm Maximum height 1.2 m before ladder	Minimum 460 mm x 460 mm Maximum 1.2 m before ladder
Walkway	Minimum clear width 650 mm Slope - see clause 5.13(2)	Minimum clear width 600 mm Slope - see clause 5.13(2)

### 5.5 Arrangement of escapes in accommodation spaces

An escape path must:

- (a) be as direct as possible; and
- (b) have a minimum number of changes in direction.

## EVACUATION

### 5.6 Evacuation paths

- (1) Escapes on a vessel must provide access to an evacuation path.
- (2) A vessel must have evacuation paths allowing the ready and rapid movement of persons from every normally occupied space on the vessel, through assembly stations if required by clause 5.8, to the survival craft embarkation stations.
- (3) An evacuation path must comply with the size requirements of Table 20 and Annex A.
- (4) For a vessel that carries passengers, at least one of the evacuation paths from each passenger space must be arranged to enable a person to reach an assembly station or open deck without having to climb more than two decks up or down.

**Table 20 — Size of evacuation paths**

Description of path	Determination of size for the purposes of Annex A		Minimum width Sized in accordance with Annex A - minimum width of:
	Along path	At end of path	
To a survival craft embarkation station without an assembly station	Cumulative number of persons, taking into account size of adjacent spaces, additional persons from adjoining spaces, percentage persons through the particular escape	Combined capacity of survival craft at the embarkation station	700 mm
To an assembly station	Cumulative number of persons entering into the path leading to the assembly station, taking into account additional persons from adjoining spaces, percentage persons through the particular escape	Proportion of total number of persons assigned to the assembly station that would enter along that evacuation path	900 mm
Between an assembly station and a survival craft embarkation station	Maximum capacity of the largest survival craft served by the assembly station	Maximum capacity of the largest survival craft served by the assembly station	900 mm

## 5.7 Alternative means of evacuation by analysis–

For a vessel that carries more than 36 passengers, compliance with clauses 5.2, 5.3, 5.4, 5.5 and 5.6 may be demonstrated via 5.7 (a) and (b).

- (a) the arrangements for evacuation paths must be evaluated by an evacuation analysis early in the design process; and
- (b) the analysis must:
  - (i) identify and eliminate, to the extent practicable, congestion during an abandonment from the movement of passengers and crew along escape routes, including crew moving along the routes in a direction opposite the movement of passengers; and
  - (ii) demonstrate that arrangements are sufficiently flexible if certain evacuation paths, assembly stations, embarkation stations or survival craft are unavailable because of a casualty; and
  - (iii) identify that all persons onboard can reach an assembly station or embarkation station within 12 minutes of being notified of a hazardous or emergency situation.

NOTE Allowing 12 minutes to reach the embarkation station assumes that it will take a further 5 minutes to muster and launch the life rafts (or lifesaving appliances), meeting the HSC Code of evacuation time of 17 minutes.

## 5.8 Assembly stations

- (1) For all vessels, the evacuation path must include at least 1 clearly marked designated assembly station.

NOTE 1. A designated assembly station for a small non-passenger vessel could be indicated by a designated drawing or diagram contained within the vessel's SMS for new employee inductions, whereas a passenger vessel should have the area clearly marked and signed similar to that contained within Annex B.

NOTE 2. Assembly station is a defined term within NSCV Part B. Often assembly stations on a small vessel are multi-use spaces or decks.

- (2) For vessels carrying 36 or more passengers, at least one alternative assembly station must also be provided in case the primary assembly station is inaccessible. The alternative assembly station can be designed to meet the requirements of subsection (4)(b) requirements as a minimum but would preferably meet subsection (4)(a).
- (3) Assembly stations must be located close to the embarkation stations and not be located in way of the machinery spaces or other spaces with a high fire risk unless the boundaries between the high-risk areas and the assembly station is insulated to the fire protection requirements in NSCV C4.
- (4) An assembly station must have
  - (a) for Class 1 vessels – at least 0.35 m<sup>2</sup> per person clear deck space to accommodate all persons assigned to it: and
  - (b) for Class 2 and 3 vessels – at least 0.25 m<sup>2</sup> per person clear deck space to accommodate all persons assigned to it.

## 5.9 Survival craft embarkation stations

- (1) The number and arrangement of embarkation stations must be sufficient to ensure the launching of all survival craft with their maximum allowable number of persons on board within 30 minutes after the abandon ship signal is given.
- (2) An embarkation area must accommodate the number of persons expected to use the area.
- (3) A vessel must have the following means of embarkation:
  - (a) an embarkation ladder or other means of enabling the embarkation of persons into survival craft at each embarkation station to achieve the time mentioned in subsection (1);
  - (b) the arrangements for embarkation must remain effective when the vessel is in the lightest seagoing condition under unfavourable conditions of trim of up to 10 and a list of up to 20 either way; and
  - (c) if it complies with subsection (1) - means for embarkation into survival craft need not be provided at the embarkation station on a vessel having a freeboard between the intended embarkation station and the waterline in the worst condition of loading, trim and heel of not more than 1.5 m.

## 5.10 Doors and hatches in escape or evacuation routes

- (1) A door in an escape or evacuation route:
  - (a) for a door of an individual cabin - may open into the cabin; and
  - (b) for a door in a stair tower - may open out of the tower, **however for uni-directional flow the doors should open in the direction of flow**; and
  - (c) in any other case - must open in the direction of escape or evacuation.
- (2) Doors or hatches on a vessel must:
  - (a) for a door or hatch in an escape route or a designated evacuation path - unlock automatically in the direction of escape or evacuation; and
  - (b) for a door to a cabin - unlock without a key from inside the room.
- (3) A vessel must have the following:
  - (a) means of preventing the unauthorised access of persons onto the vessel when it is unmanned that do not compromise the effectiveness of escape and evacuation routes, other than a primary access door;
  - (b) locking mechanisms located to allow rapid and reliable release in the direction of escape or evacuation without the need for a key or special tool; and
  - (c) arrangements to ensure covers of escape and evacuation openings are operable from both sides when the vessel is manned.
- (4) A door that provides high-capacity escape from public spaces for 110 persons or more (ie of width exceeding 1200 mm) that is normally latched

must have a quick release mechanism in the direction of escape that may be activated by:

- (a) a panic bar; or
  - (b) a mechanism for rapid and reliable release by a single person.
- (5) A doorway from an alternative escape route must be of a height and size mentioned in Table 21.

**Table 21 — Minimum size of doorways or openings forming alternative escape routes**

Maximum number of persons intended to pass through	Minimum height (mm)	Minimum width (mm)
25	1220	815
20	1220	610
15	1120	510
10	915	510
5	660	485

PASSAGEWAYS, WALKWAYS, STAIRWAYS AND GANGWAYS

**5.11 Passageways**

- (1) A passageway on an evacuation path must be sized in accordance with clause 5.6.
- (2) A passageway in an accommodation space or operational space must be arranged to facilitate the rapid movement of persons to the evacuation path.
- (3) The width of a passageway used for low-capacity access and escape must comply with Table 22.

**Table 22 — Minimum width of passageways between furniture or fittings**

Length of passageway (m)	Numbers of persons served by the passageway	Minimum width of passageway for single direction flows (mm)	
		Less than 640 mm from the floor <b>(A in Figure 6)</b>	640 mm or more from the floor <b>(B in Figure 6)</b>
≥4.5 m	1 to 5	380	510
	6 to 10	510	600
	11 to 18	600	700
<4.5 m	1 to 5	305	510
	6 to 10	380	510
	11 to 18	510	600



**Figure 6** — Minimum width of passageways for escape routes

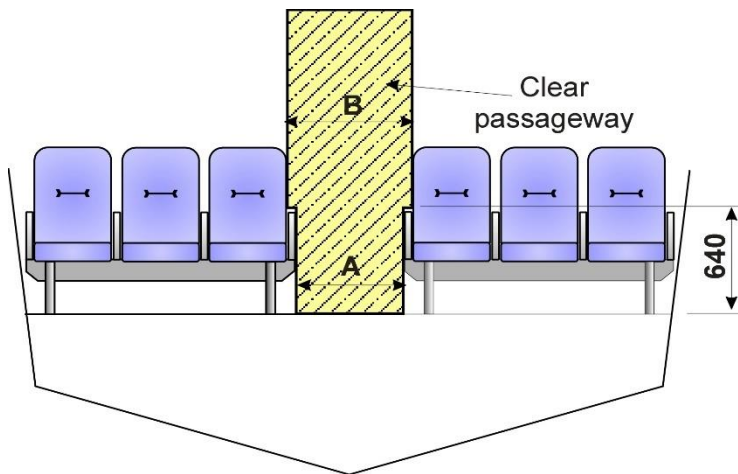

- (4) A passageway in a ro-ro space or deck that a passenger can access must:
  - (a) be permanently marked to prevent obstruction by vehicles; and
  - (b) have a clear width of at least 600 mm.
- (5) An accessway used only for occasional access by the crew on inspection or maintenance need not comply with subsections (2) and (3).

### 5.12 Handrails

- (1) A handrail or other handhold must be provided:
  - (a) for each walkway, stairway and ladder; and
  - (b) along an evacuation route facilitating persons to move quickly to assembly stations and embarkation stations if the deck is at an angle.
- (2) A handrail along a high-capacity route must be located within 5% of:
  - (a) 50 mm clear of the adjacent bulkhead; and
  - (b) 865 mm above the upper surface of:
    - (i) the deck, or
    - (ii) the nosing of a stair tread.
- (3) Handrails must be provided on both sides in the following locations:
  - (a) longitudinal corridors and walkways more than 1800 mm in clear width;
  - (b) transverse corridors and walkways more than 1000 mm in clear width; and
  - (c) ladders and stairways.
- (4) Handrails and other handholds and their means of attachment must be designed to withstand the following loads:

- (a) a distributed horizontal load of 750 N/m applied in the direction of the centre of the corridor or space; and
- (b) a distributed vertical load of 750 N/m applied in the downward direction.

### 5.13 Walkways, stairways and ladders – general requirements

- (1) A walkway, stairway or ladder must be provided if:
  - (a) the difference in height between 2 levels exceeds 750 mm; and
  - (b) persons are likely to need to move between the 2 levels.
- (2) The angle of the walkway, stairway or ladder must be within the range mentioned in:
  - (a) column 2 of Table 23; and
  - (b) if the walkway, stairway or ladder is used as a high-capacity escape – column 3 of Table 23.

**Table 23 — Angles to the horizontal of walkways, stairways and ladders and limits on their application (see also [Figure 7](#))**

Description	Range of angles to horizontal (degrees)	Range of angles to horizontal for high-capacity escape (degrees)	Preferred angle to horizontal (degrees)
Walkway	0 to 20	0 to 10	0 to 10
Stairway	20 to 45	30 to 45	30 to 38
Step ladder	60 to 70	Not applicable	60 to 70
Rung Ladder	70 to 90	Not applicable	70 to 75

**Figure 7** — Angles to the horizontal of stairways, walkways and ladders and limits on their application (see also Table 23)

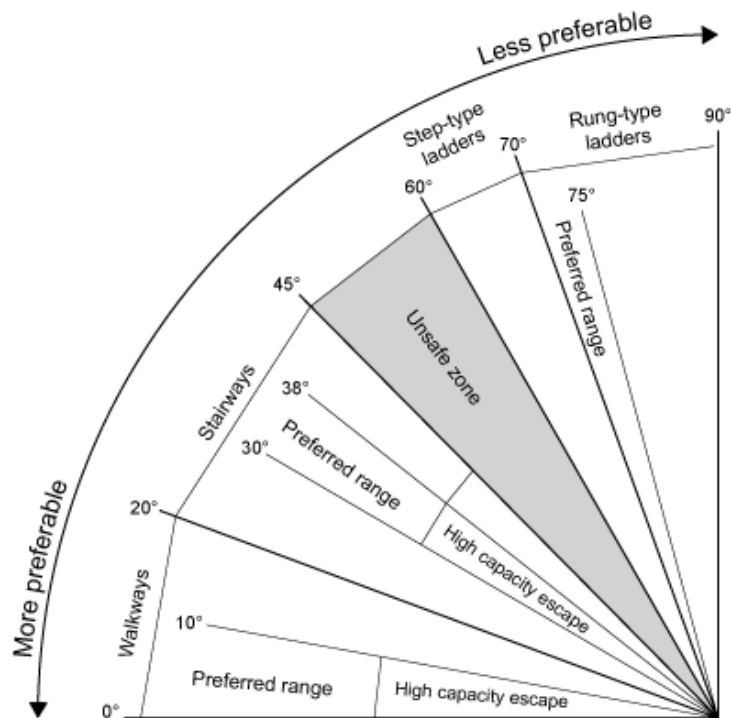

#### 5.14 Stairways

- (1) A stairway sized for more than 90 persons must be aligned fore and aft.
- (2) A stairway must not exceed 3.5 m in vertical rise without an intermediate landing.
- (3) If a landing is required under subsection (2), it must:
  - (a) be at least 2 m<sup>2</sup> in area; and
  - (b) increase by 1 m<sup>2</sup> for every 10 persons provided for in excess of 20 persons; and
  - (c) not exceed 16 m<sup>2</sup>.

**(4) Steps forming a stairway must:**

- (a) comply with Table 24 and the characteristics of Figure 8;
- (b) have a constant rise;
- (c) be within the tolerance range permitted by AS 1657:2018; and
- (d) be designed to take the intended load.

NOTE All risers and going on the same flight of stairs should have uniform dimensions within a tolerance of  $\pm 5\text{mm}$ .

**Table 24 — Required dimensions of steps in stairways**

Characteristic	Steps for high-capacity escapes (mm) (Based on NCC Vol 2 safe movement and access)	Steps for low-capacity escapes (mm) (Based on AS 1657- 2018)	Spiral Steps (mm) (Based on NCC Vol 2 safe movement and access)	Preferred values (mm)
Rise (R)	115 to 190	130 to 225	140 to 220	190
Going (G)	240 to 355	215 to 355	210 to 370	275
Slope relations (2R + G)	550 Min 700 Max	540 Min 700 Max	590 Min 680 Max	625
Tread depth (min)	185	185	See NCC Vol 2 safe movement and access	n/a
Overlap on tread	≥ 30 if G < 254. 0 if G ≥ 254			n/a

**Figure 8 - Dimensions of steps in stairways**

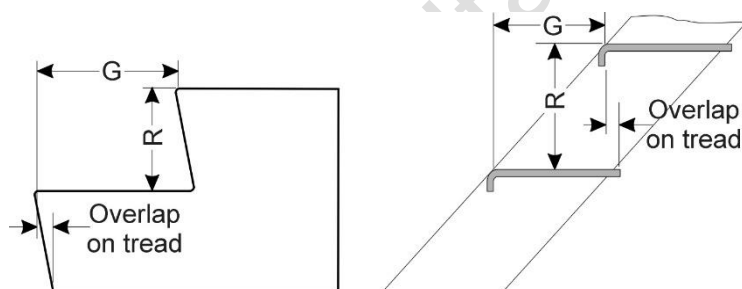

- (5) The application of spiral stairways is subject to the same constraints as apply to a step ladder in Table 16.
- (6) Spiral stairways having an internal diameter less than 2440 mm must not be used for high-capacity escapes.
- (7) Tapered treads forming winders and spiral stairways must comply with Table 24 assuming the going is measured at the following point:
  - (a) for a tread up to 1 m wide — the middle of the unobstructed width of the stair (see Figure 9); and
  - (b) for a tread more than 1 m wide — 400 mm from the unobstructed width of each side of the stair (see Figure 9).

**Figure 9 — Tapered treads**

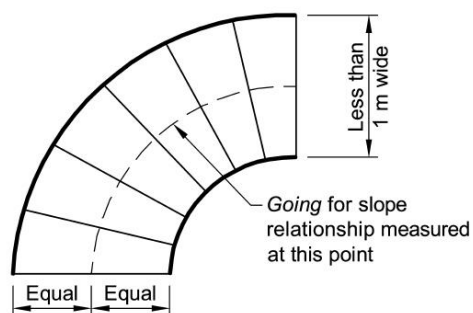

**Tapered treads — 1 m or more in width**

**Figure 8 a)**

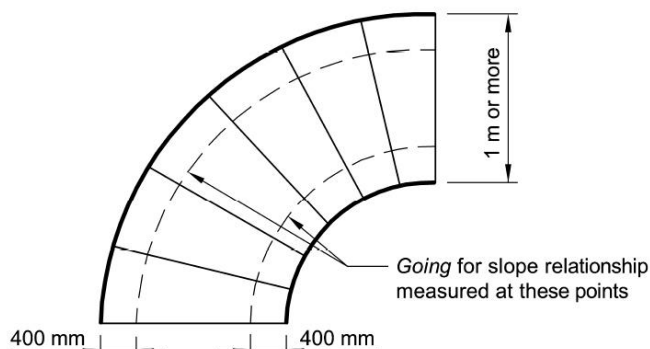

**Figure 8 b)**

- (8) A stairway must be designed and constructed to withstand a vertical pressure that is within the range of the design pressure applicable to the decks connected by the stairway.
- (9) Handrails must be fitted in accordance with Table 25.

**Table 25 — Handrails**

Stairway	Handrail to be fitted
Stairways forming part of a low-capacity escape route	(a) A handrail on at least 1 side in accordance with clause 5.12; or (b) If the height of the stairway is less than 1.5 m - suitable hand holds for use in either direction of travel
Stairways forming part of a high-capacity escape	Handrails on both sides in accordance with clause 5.12
Stairways with more than 1800 mm clear width between handrails	Intermediate hand rails spaced not more than 1800 mm apart

**5.15 Ladders**

- (1) A ladder must meet the following dimensional requirements:
  - (a) the width between stringers must be at least 400 mm (see Figure 10),
  - (b) treads or rungs must be equally spaced except that the height to the lowest tread may be reduced by up to 15%; and

- (c) treads or rungs must be spaced between 200 mm and 300 mm apart, measured vertically (see Figure ).
- (2) The treads of a step ladder must have a going of at least 100 mm (see Figure 10).
- (3) The horizontal distance between each tread or rung of a ladder and an adjacent bulkhead must be at least 150 mm.
- (4) A ladder must not exceed 6 m in vertical rise without a landing.
- (5) A ladder or handrail must be constructed as follows:
  - (a) it must be able to withstand a vertical concentrated loading of at least 1 kN;
  - (b) it must be constructed of material of adequate strength and stiffness and securely attached to the structure by stays;
  - (c) the treads must be securely and permanently secured to the stringers;
  - (d) if its stringers are flexible steel wire ropes - it cannot be constructed as an escape route;
  - (e) the method of support and length of stays must reduce vibration to a practical minimum.
- (6) A rung ladder must not be skewed by more than 2° (see Figure 10).

**Figure 10 — Ladder details**

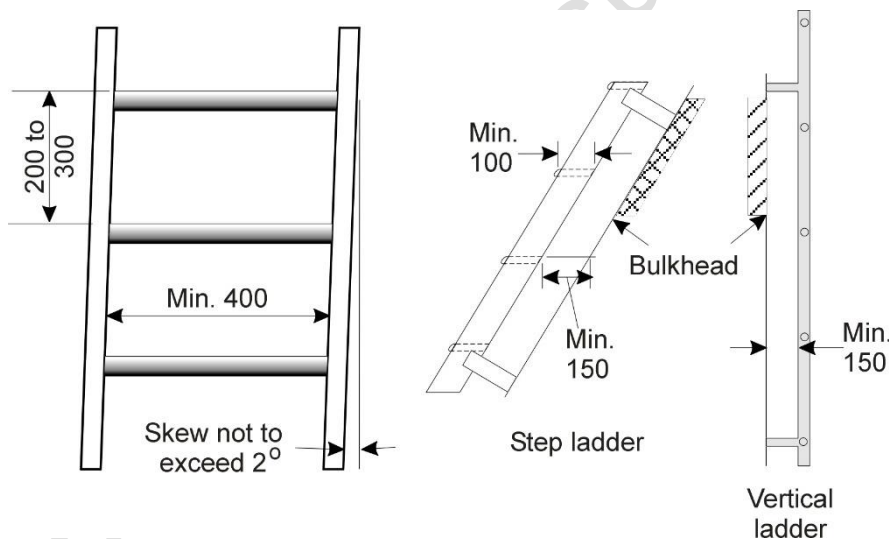

- (7) A step ladder must have handrails of substantial construction on both sides in accordance with clause 5.12, fitted at a convenient distance above the treads.
- (8) A ladder in a cargo hold must be designed and arranged so that the risk of damage from cargo handling gear is minimised.

## SAFETY INFORMATION

### **5.16 Safety information and escape marking**

#### Class 1 vessels

(1) Where compartments, decks (open or enclosed), or spaces on the vessel under normal operation contain more than 12 persons, the number of passengers permitted within the compartment, deck or spaces must be indicated on signage placed in a visible location at the entry or within the space, deck or compartment.

(2) The Signage required by 5.16 (1) must be a minimum of A7 (7 cm x 10 cm).

NOTE This requirement is designed to ensure that the number of persons in a space or on a deck does not compromise the safety of a vessel and the persons on it. For example, an upper open passenger deck could impact the safety of the vessel if it was overloaded with people, and a small compartment with only a low-capacity escape cannot safely hold more persons than can be evacuated quickly.

(3) The following locations must be clearly and permanently marked so that their location is obvious in daylight, at night and in conditions of smoke.

- (a) escapes from spaces intended to contain more than 12 persons;
- (b) assembly stations if required by clause 5.8; and
- (c) entrances to evacuation routes.

(4) In addition to paragraph (2), for a vessel carrying more than 12 berthed persons, or 36 or more passengers, which is not fitted with emergency lighting complying with Part C Subsection 5B illuminating evacuation routes, exits, assembly stations and lifesaving appliances, the following spaces must be marked with low location lighting (LLL):

- (a) an escape route from an accommodation space; and
- (b) either:
  - (i) a route to an assembly station; or
  - (ii) an evacuation route to an embarkation point; or
  - (iii) both (i) and (ii).

(5) Low location lighting must either:

- (a) comply with ISO 15370:2021 Low Location Lighting (LLL); or
- (b) be installed as follows:
  - (i) the Low Location Lighting must be placed not more than 300 mm above the deck at all points of the route including angles and intersections;
  - (ii) if power operated, the low location lighting must be arranged so that a failure of any single light or cut in a lighting strip will not result in the marking being ineffective;

- (iii) the low location lighting must be visible by day and by night, and for vessels carrying more than 36 passengers, in smoke-filled conditions; and
  - (iv) each lighting strip must procedure an output of at least 1000 Lumens per meter of brightness for LLL with a power source or the photoluminescent performance marking requirements of Table 26.
- (6) In order to comply with the requirement for visibility in night and smoke-filled conditions, as applicable to the vessel, the appropriate type of marking in accordance with Table 26 must be used.

**Table 26 - Requirements for marking of escapes**

Type of marking	Areas requiring marking
	1. Escapes; 2. Assembly stations; 3. Entrances to evacuation routes; 4. Evacuation paths
Low location lighting supplied by a central emergency power source (Example: Generator)	Class 1 vessels ≥ 36 pax or 12 berthed pax
Low location lighting supplied by a self-contained emergency power source (Example: Battery)	Optional for class 2 and 3 vessels
Photoluminescent marking (minimum luminance of 30 mcd/m <sup>2</sup> for not less than 90 minutes)	Class 1 vessels <36 pax and Class 2 and 3 vessels

- (7) Markings must remain visible for at least the greater of:
- (a) the time mentioned for emergency lighting in Part C Subsection 5B; or
  - (b) 2 hours.
- (8) Markings for escape and evacuation must comply with either:
- (a) For Class 1 vessels carrying more than 12 berthed passengers or more than 36 day passengers;
    - i. SOLAS Chapter II-2 – Construction – Fire Protection, Fire Detection and Fire Extinction - Part D – Escape; and
    - ii. *IMO Resolution A.1116(30)*.
  - (b) For Class 2 and 3 vessels carrying less than 12 passengers.
    - i. Comply with Annex B.

### 5.17 Instruction for safe escape

- (1) This clause applies to a vessel:
- (a) carrying at least 12 berthed passengers; or
  - (b) carrying at least 36 day passengers.



- (2) On a vessel with 4 or more deck levels:
  - (a) each deck must be sequentially numbered, starting with '1' at the tank top or lowest deck; and
  - (b) the numbers must be prominently displayed at stair landings and lift lobbies.
- (3) A vessel must have directions for rapid escape and evacuation as follows:
  - (a) simple 'mimic' plans, showing the 'you are here' position and escape routes marked by arrows, must be prominently displayed on the inside of each cabin door of berthed accommodation and in public spaces; and
  - (b) the plan must be properly oriented in relation to its position on the vessel showing:
    - (i) the directions of escape; and
    - (ii) the location of primary and any secondary means of escape; and
    - (iii) the number of the crew or passengers normally occupied within the space; and
    - (iv) the location of the relevant assembly stations and survival craft embarkation positions.

## CHAPTER 6 PERSONAL SAFETY

### 6.1 Application

This Chapter applies to all vessels.

### DEEMED TO SATISFY SOLUTIONS

#### PROTECTION OF PERSONS FROM THE ELEMENTS

### 6.2 Protection of persons from the elements

- (1) The means of safe passage on a vessel that is not subject to the Load Lines Convention must:
- (a) be appropriate to the demographic of persons (eg crew, passengers or others) likely to be exposed to the sea, and the likelihood of exposure; and
  - (b) comply with Table 27.

NOTE The Load Lines Convention has requirements for the protection of the crew and the means for safe passage of the crew on vessels to which it applies.

**Table 27 — Requirements for means of safe passage across exposed decks**

Measure	Deck subject to seas coming on board in normal conditions		Deck subject to seas coming on board only in abnormal conditions	
	Passengers	Crew	Passengers	Crew
Underdeck passages	Acceptable	Acceptable	Acceptable	Acceptable
Raised gangways	Acceptable	Acceptable	Acceptable	Acceptable
Harness, safety lines, clipping points and jack-stays - see clause 6.9	Not acceptable	Acceptable	Acceptable	Acceptable
Guardrails or handrails	Not acceptable	Not acceptable	Acceptable	Acceptable
Lifelines	Not acceptable	Not acceptable	Not acceptable	Acceptable

- (2) The following vessels must be provided with a cabin, enclosure or other permanent rigid structure to protect those on board from the weather:
- (a) an Operational Area A vessel;
  - (b) an Operational Area B or C vessel engaged on a voyage of at least 12 hours; and

- (c) a sheltered water vessel (Operational Areas D or E) engaged in voyages of at least 36 hours.

### 6.3 Safe movement of persons on vessels

#### *Stairways and ladders*

- (1) Stairways and ladders for general access not forming part of escape or evacuation routes must comply with clause 5.13.
- (2) A suspended walkway that is more than 10 mm from a permanent structure and from which an object could fall more than 2 m must have a toe board at least 60 mm above the top surface.
- (3) A stairway, ladder, suspended walkway or handrail that is used only by the crew for tending plant, may comply with either this clause 6.3 or *AS 1657-2018 - Fixed platforms, walkways, stairways and ladders — Design, construction and installation*.

#### *Walking surfaces*

- (1) Floor plates, gratings, ladders or other removable walking surfaces must be securely fitted and have a slip-resistant surface.
- (2) Openings located in walking surfaces causing an unacceptable risk of injury must have guardrails or other means of protection

#### Lighting

- (1) In addition to clause 4.8, there must be adequate natural light, or fixed artificial light, in all areas of the vessel that require it for normal operations or passenger movement.

NOTE The applicable approved Code of practice that has covers workplace lighting is the *Code of Practice - Managing the work environment and facilities* and it provides additional guidance for anyone who has a duty of care

### 6.4 Bulwarks and guardrails

- (1) A vessel must have bulwarks or fixed guardrails near the periphery of an exposed deck that a person or vehicle may access unless the deck is a nominated special purpose deck or special working deck that complies with clause 6.5.
- (2) The minimum height of bulwarks and guard rails on a vessel must be in accordance with Table 28.

**Table 28 — Heights of bulwarks and guardrails**

Vessel measured length	General purpose deck (mm)	Special purpose deck (mm)	Special working deck (mm)
> 16 m	1000	800	600 as one option in <b>Table 30</b>
≤ 16 m	800	600	600 as one option in <b>Table 30</b>

- (3) Where fixed guardrails are used, they must comply with the following:
- (a) a horizontal course must have an angle to the horizontal of not greater than 30°;
  - (b) for a guardrail with intermediate horizontal courses - the courses are arranged so that the spacing between courses does not exceed the values mentioned in Table 29; and
  - (c) for a guardrail constructed without horizontal courses - the courses are arranged so that the maximum gap between palings, bars or other barrier elements does not exceed that which would allow a 125 mm diameter sphere to pass through the gap.

**Table 29 — Maximum permissible clear opening between horizontal courses**

Location	Maximum permissible opening (mm)			
	General purpose deck accessible by passengers with children less than 12 years old	General purpose deck for crew or passengers without children less than 12 years old	Special purpose deck	Special working deck
Between lowest course and the deck	230	230	230 to 300	Not specified
Between other courses	230	380	380	Not specified

- (4) An opening in a bulwark, including a freeing port, must be protected by bars or other barrier elements to limit the maximum dimension of any clear opening to no greater than that mentioned for guardrails in subsection (3).
- (5) On a Class 1 vessel, an opening in a bulwark or guardrail on a deck that is accessible by passengers less than 12 years old, must be fitted with arrangements that limit the size of a single clear opening below the top of the rail to not more than would allow the passage of a 125 mm diameter sphere.

- (6) A guardrail must meet the following design and construction requirements:
- (a) a guardrail, other than one mentioned in subsection (7), must be designed and constructed to withstand a point load of 890 N applied at any point in any direction, and a uniform load of 725 N/m applied to the top rail in any direction;
  - (b) if the guardrail includes a gate, it must meet the criteria with the gate open; and
  - (c) if glass is used in the construction of the guardrail, the design and construction of the guardrail must comply with Lloyd's Rules.
- (7) A guardrail formed by horizontal courses of flexible wire may be fitted on a Class 1 vessel of less than 24 m length or a Class 2 or 3 vessel subject to subsection (9).
- (8) Stanchions must be designed, arranged and constructed as follows:
- (a) the maximum spacing between stanchions must not exceed 2150 mm;
  - (b) the horizontal courses must not pass outboard of a line angled at 10° from the vertical from a point located 50 mm above the intersection of the deck and the hull side; and
  - (c) the guardrail stanchions without courses must achieve the following when tested with the forces directed outboard at the point of intersection with the uppermost course and perpendicular to the guardrail direction at that point:
    - (i) the deflection must not exceed 50 mm at the point of application of the force when a horizontal force of 280 N is applied;
    - (ii) there must be no permanent deformation of the stanchion after the force mentioned in subparagraph (i) has been removed; and
    - (iii) the stanchion must withstand a horizontal force of 560 N without breaking.
- (9) A vessel must have the following measures for flexible horizontal courses:
- (a) each course of flexible wire or similar material used to form horizontal courses must have a minimum ultimate breaking strength of 13 kN for Operational Area A or B, or 9 kN for Operational Area C, D or E;
  - (b) arrangements for tensioning to keep horizontal courses taut must be incorporated into the guardrail, of strength not less than the material used in the horizontal course; and
  - (c) the flexible wire or similar material used to form horizontal courses must be arranged so that it is visible for inspection purposes.

## SPECIAL PURPOSE AND SPECIAL WORKING DECKS

### 6.5 Nominated special purpose and special working decks

A special purpose deck or special working deck must be provided with additional measures to maintain safety:

- (a) in accordance with Table 30; and
- (b) that are expressly documented in the vessel's safety management system.

**Table 30 — Additional requirements for nominated special purpose and special working decks**

Requirement	Special purpose deck		Special working deck	
	Seagoing Operational area A, B or C	Sheltered waters Operational area D or E	Seagoing Operational area A, B or C	Sheltered waters Operational area D or E
<b>Measure 1</b> Slip-resistant surface (see clause 6.6)	Applies	Applies	Applies	Applies
<b>Measure 2</b> Foot-stop/toe rail if guard rail fitted (see clause 6.7)	Applies	Applies	Applies	Applies
<b>Measure 3</b> Handholds (see clause 6.8)	Applies	Applies*	Applies	Applies*
<b>Measure 4</b> Guardrails/bulwarks of minimum height in accordance with Table 28	Applies	Applies	Applies	Either Table 28 or clause 6.9
<b>Measure 5</b> Harnesses, safety lines, clipping points and jack-stays (see clause 6.9)	Applies	Either clause 6.9 or wearing of lifejackets on deck,	Applies	Either clause 6.9 or wearing of lifejackets on deck
<b>Measure 6</b> Fixed seating for all persons on special purpose/special working deck (see clause 4.14)	Applies	Applies	Not Required	Not Required
<b>Measure 7</b> Wearing of lifejacket when on	Applies	Either wearing of	Applies	Either wearing of

Requirement	Special purpose deck		Special working deck	
	Seagoing Operational area A, B or C	Sheltered waters Operational area D or E	Seagoing Operational area A, B or C	Sheltered waters Operational area D or E
special purpose/ special working deck		lifejackets or clause 6.9		lifejackets or clause 6.9
<b>Measure 8</b> Crew must wear b) in conducting single handed operations and a) for multiple crew operations; a) a person overboard alert device complying with AS/NZS 4869; or b) a personal locating beacon complying with AS/NZS 4280.2 and must be registered with AMSA.	Applies	Not required	Applies	Not required
<b>Measure 9</b> Means of reboarding (see clause 6.10)	Applies	Applies	Applies	Applies

\*Alternative arrangements for Class 2 unpowered/non-self propelled barges operating in sheltered waters and not able to comply with table 30 fully;

- (a) barges with no superstructure within 2 m of the edge of the vessel don't require measure 3.
- (b) Barges limiting access to all personnel within 1 m of the side of the vessel don't require measure 4 but must comply with either measure 5 or 7 and must comply with 1, 8 and 9.

## 6.6 Slip resistant surfaces

A special purpose deck or special working deck must have the following measures for slip resistant surfaces:

- (a) deck areas must be slip-resistant;
- (b) slip-resistant surfaces need not be continuous; and
- (c) the maximum spacing between slip-resistant patches must not be greater than 75 mm, except for glazed areas where the maximum spacing must not be greater than 500 mm, unless the lateral sides of the area are fitted with foot stops in accordance with clause 6.7.

## 6.7 Foot stops and toe rails

- (1) A foot-stop or toe rail must be provided on a special purpose deck or special working deck:
  - (a) along those outboard edges of the accessible portion of the deck; and
  - (b) as close as practicable to the outboard edges of the accessible portions of the deck.
- (2) The foot-stops or toe rail must comply with the following:
  - (a) the height of the upper edge of the foot-stop or toe rail measured perpendicular to the adjacent working deck must be at least 25 mm; and
  - (b) if the shape of the foot-stop or toe rail is configured other than to have a vertical upstand, the foot-stop must comply with *ISO 15085:2003 — Small craft — Man-overboard prevention and recovery*.
- (3) The foot-stop or toe rail may have gaps for the following:
  - (a) stanchions;
  - (b) pulpit feet;
  - (c) cleats;
  - (d) other similar fittings;
  - (e) water drainage.
- (4) Each gap must not be greater than 100 mm to the edge of the adjacent fitting, or foot stop or toe rail.
- (5) A fitting providing a foot-stopping action is a local foot-stop or toe rail.

## 6.8 Handholds

- (1) Handholds must be provided on special purpose deck or special working deck, and may be any of the following:
  - (a) handrails;
  - (b) overhead rails;
  - (c) handles on fixed seats;
  - (d) pillars;
  - (e) cleated handrails on coachhouses.
- (2) The handholds must:
  - (a) be designed to facilitate a secure grip; and
  - (b) be located having regard to the demographic characteristics of a person likely to use them; and
  - (c) not be spaced more than 1.5 m apart; and
  - (d) be capable of withstanding a horizontal force of 1500 N without any permanent yield or rupture.



## 6.9 Harnesses, safely lines, clipping points and jack-stays

- (1) If it is the applicable measure in accordance with Table 30, the vessel must comply with this clause.

### *Harnesses and safety lines*

- (2) The vessel must have on board:
  - (a) at least 2 harnesses; and
  - (b) a safety line of appropriate length for each person who is to use a special purpose deck or special working deck that complies with:
    - (i) AS 2227-2006 - Yachting harnesses and lines - Conventional lines; or
    - (ii) for vessels  $\leq 24\text{m}$ , ISO 12401:2209 Small craft - Deck safety harness and safety line - Safety requirements and test methods

### *Clipping points*

- (1) For an accessway leading onto a special purpose deck or special working deck, there must be clipping points or jack-stays for a person to clip on before coming on deck and unclip after going below deck.
- (2) The following applies for clipping points:
  - (a) if the option of hooking points and harnesses is adopted for a space, a clipping point must be provided at each place where persons work or otherwise occupy for long periods; and
  - (b) if a deck contains any of the features mentioned in Table 31, a clipping point must be provided within the distance mentioned in the table; and
  - (c) sufficient clipping points must also be provided so that they are located no more than 3 m apart.
- (3) A clipping point must:
  - (a) be designed to facilitate attachment by the harness hook; and
  - (b) not exceed 15 mm diameter which is the maximum permissible dimension that can be accommodated within the inside of the harness hook; and
  - (c) withstand a horizontal force of 6 kN once installed.
- (4) A Clipping point complying with the any of the following standards is an acceptable alternative:
  - (a) for vessels  $\leq 24\text{m}$ , ISO 12401:2209 Small craft – Deck safety harness and safety line – Safety requirements and test methods. Requirements for hooking points; or
  - (b) EN 795: 2012 Personal fall protection equipment – Anchor devices.

**Table 31 — Requirement to fit clipping point**

<b>Feature</b>	<b>Location of clipping point</b>
Accessways to spaces inside the vessel	Within 1 m of the outside edge of accessway
Each steering position	Within 2 m
Each mast on a sailing vessel	Within 2 m
Each winch position on a vessel (including a sailing vessel) where the winches are likely to be operated underway	Within 2 m
The windlass	Within 2 m
Towing strong point	Within 2 m
Fishing positions and game fishing chairs on sports fishing vessels	Within 2 m

**Jack-stays**

- (5) The vessel must have sufficient jack-stays allowing a person on a special purpose deck or special working deck to perform his or her functions.
- (6) A sailing vessel must have jack-stays port and starboard.
- (7) The jack-stays:
  - (a) must be arranged to minimise the need for clipping and unclipping; and
  - (b) may be in sections; and
  - (c) must have each section as long as practicable.
- (8) An attachment point must be:
  - (a) fitted at the ends of each section of jack-stay; and
  - (b) reliably attached to the structure of the vessel.
- (9) A jack-stay must be made of stainless steel wire, webbing or equivalent with breaking strength of at least 20 kN.
- (10) If made from stainless steel wire, the jack-stay must be uncoated and used without sleeving to facilitate monitoring of its condition.
- (11) An attachment point for a jack-stay must withstand a horizontal force of 20 kN applied in the direction of and up to an angle of 30° from a line connecting them.
- (12) An attachment point for a jack-stay need not be designed specifically for the purpose if it complies with subsections (8) to (13).

## 6.10 Reboarding

A vessel with a nominated special purpose deck or special working deck must have a means of reboarding that is:

- (a) accessible to, or deployable by, the person in the water without assistance from other persons and without the use of tools (eg ladders, steps, handholds, brackets); and
- (b) suited to the demographic characteristics of persons likely to need it; and
- (c) for passengers - a ladder or stairs having a lowest rung or step at least 300 mm below the worst case waterline; and
- (d) for a vessel with a special working deck but without a special purpose deck and having a minimum freeboard less than 500 mm — a single handhold, suitably located to allow reboarding, with consideration of the vessel's stability; and
- (e) installed remote from any propeller if practicable.

### PROTECT FROM HAZARDOUS PLANT

## 6.11 Hazardous plant

- (1) In this clause:

**plant** means any machinery, equipment appliance, implement or tool on the vessel, including any component, fitting or accessory.

- (2) Plant must be arranged for safe access as follows:
  - (a) the overall design of a space containing plant must be arranged to facilitate reasonable access to all items that may require inspection or attention in service;
  - (b) passageways passing close to potentially hazardous elements of plant must be of sufficient width to minimise the risk of exposure to the hazards.
- (3) A vessel must have shields and guards to protect a person from exposure to hazardous elements of plant including moving parts, hot and cold surfaces and toxic substances in both normal and abnormal conditions of operation.

### ACCESS TO AND FROM THE VESSEL

## 6.12 Access to and from the vessel

- (1) Appropriate means of access to and from the vessel must be provided, to facilitate the safe boarding and disembarkation of persons.
- (2) The means of access must:

- (a) be landed clear of the edge of the wharf or other potential hazards such as mooring lines; and
- (b) be positioned at an angle that will allow safe access to the vessel; and
- (c) be of strength sufficient to withstand loads in normal and abnormal conditions; and
- (d) be adequately secured to prevent accidental displacement; and
- (e) be positioned away from potentially hazardous activities such as cargo handling operations; and
- (f) allow for likely variations in quay levels, tidal levels and vessel freeboard; and
- (g) be able to be adjusted to allow for changing tidal levels and vessel freeboard if the access is to be deployed for longer periods; and
- (h) be illuminated throughout its length if used during the hours of darkness; and
- (i) protect persons from falling from the means of access, either from a height onto the wharf or between the vessel and the quayside.

NOTE Additional guidance that may assist in managing the risks are contained in the note at 7.13 (3).

### 6.13 Gangways and accommodation ladders

- (1) When a gangway or accommodation ladder is fixed or attached to the vessel as part of the vessel's equipment it must be of sufficient length to ensure that when deployed during normal operations over the normal range of tide and vessel freeboards:
  - (a) the landing of the gangway or accommodation ladder is kept well clear of the edge of the quayside; and
  - (b) the angle of the gangway does not exceed the maximum permissible angle for cleated inclined ramps of 30°; and

NOTE For vessels providing public transport or catering for people with low mobility, the gangway angles will need to be reduced.

  - (c) the angle of the accommodation ladder does not exceed the maximum permissible angle of 55°.
- (2) A gangway or accommodation ladder, if carried on the vessel as part of the vessel's equipment, must comply with:
  - (a) ISO 7061:2015 — Shipbuilding — Aluminum shore gangways for seagoing vessels; or
  - (b) ISO 5488:2015 Ships and marine technology - Accommodation ladders: or for vessels only operating in D and E; or
  - (c) BS EN 14203: 2003 Inland navigation vessels. Gangways for passenger vessels. Requirements, tests; or
  - (d) DS EN 526:1995 Inland navigation vessels. Gangways with a length not exceeding 8 m. Requirements, types; or

(e) an Equivalent Australian standard

EXAMPLE Access structures compliant to AS 1657:2018 Fixed platforms, walkways, stairways and ladders - Design, construction and installation may be suitable in some circumstances.

(3) Any means of access provided by a port authority or other person must comply with clause 6.12.

NOTE Additional guidance that may assist in managing the risks are:

- ILO Code of Practice: Safety and health in ports (Section 3.4 - Shore-side access to ships)
- Working Safely on the Waterfront – Safe Work Australia
- Code of Practice – Managing the work environment and facilities - Safe Work Australia
- Code of Practice – Managing the risk of falls at the workplace – Safe Work Australia

## PILOT TRANSFER AND LAUNCH ARRANGENTS

### **6.14 Pilot transfer arrangements**

A seagoing vessel of at least 50 m measured length must have safe pilot transfer arrangements complying with Regulation 23 of Chapter V of SOLAS in:

- (a) operational Area A; and
- (b) operational Area B; and
- (c) if the vessel is not to operate with a pilotage exemption — operational Area C.

### **6.15 Pilot launches**

- (1) A pilot launch must be constructed so that:
  - (a) the deck that is used for access to the pilot transfer position is clear and free of obstructions; and
  - (b) there is at least 750 mm between the gunwale and deckhouse or superstructure on the deck that is used for access to the pilot transfer position; and
  - (c) the pilot transfer position is forward of the wheelhouse; and
  - (d) from the launch master's normal driving position, the pilot and deck hand can be seen when they are outside the cabin; and
  - (e) a person in the launch master's normal driving position has, as far as is practicable, a clear view at every stage, of a pilot or deck hand moving from the cabin to the pilot transfer position or transferring the pilot's bags to or from the vessel; and
  - (f) a person in the launch master's normal driving position can see the pilot:
    - (i) when leaving the deck of the pilot launch and when ascending the pilot ladder; and
    - (ii) when descending the pilot ladder and arriving on the deck of the pilot launch; and

- (g) the helm, engine controls and all other launch handling controls are at the normal driving position; and
- (h) normal access from the open deck to accommodation space for use of pilots is not through a forward-facing weather tight door; and
- (i) all external walkways have an efficient non-slip surface; and
- (j) the external colour is substantially a highly visible colour and clearly marked with the word 'pilot' on both sides of the vessel in letters at least 300 mm high.

(2) For the purposes of subsection (1)(j), the highly visible colour must either:

- (a) comply with the definition of highly visible colour contained in the LSA Code for life-saving appliances; or
- (b) be of an international or vivid reddish orange, safety yellow, or a comparably highly visible colour that would assist detection at sea.

NOTE 'Highly visible colour' only includes colours of strong chromatic content. Colours such as white, all shades of grey and all shades of blue will not be accepted as 'comparable' colours.

(3) A pilot launch must be fitted with the following:

- (a) for each seafarer on board the launch and for each pilot carried so that all people on board the launch may be seated simultaneously — 1 impact absorbing seat fitted with adjustable suspension and dampers to reduce shock loads and vibration;
- (b) seats allowing comfortable access to any controls and equipment required to be used by the launch master, seafarers or pilots;
- (c) a working air conditioner that can maintain a temperature in the range of 21°25°C inside the cabin in all ambient weather conditions in the area of operation; and
- (d) sound proofing so that ambient noise levels inside the accommodation, except the engine space, do not exceed 85 dB when measured:
  - (i) at the height approximately equal to the level of a person's head while sitting in the impact absorbing seats provided; and
  - (ii) with the engines running at normal sea-going operating revolutions; and
  - (iii) with the doors closed; and
  - (iv) with the air conditioner running.

(4) A pilot launch must be fitted with the following equipment:

- (a) fendering that:
  - (i) allows the pilot launch to come alongside vessels underway in all normal operating conditions without sustaining damage; and
  - (ii) does not interfere, obstruct or hinder pilot transfer; and
  - (iii) is continuous along gunwales; and

- (iv) is not constructed using material that can become fouled on the pilot ladder or recovery line;
- (b) onboard lighting sufficient to ensure that operations can be conducted safely;
- (c) safety handrails on deck and inside the accommodation that are:
  - (i) capable of withstanding a load in either the vertical or horizontal direction of at least 1.2 kN; and
  - (ii) situated both inside and outside of the cabin so that a person can leave any of the impact absorbing seats provided in the cabin and move to the pilot transfer area with the continuous aid of the handrails; and
- (d) an uninterrupted, continuous safety rail system;
  - (i) which a lanyard or webbing strap capable of withstanding a load of 6 kN, or complying with AS 2227 or ISO 12401, may be attached; and
  - (ii) that when connected to a safety tether (complying with clause 7.9) does not allow the Marine pilot or crew members torso to reach the edge of the pilot vessel when attached to the travellers of the safety rail attached and clipped to a harness complying with clause 7.9; and  
EXAMPLE See figure 11 for an illustration.
  - (iii) that is located on each side of the accommodation to the pilot transfer area; and
  - (iv) for which pre-installation testing or certification has provided evidence that the safety rail can withstand a static load test with a horizontal or vertical force of at least 6 kN load in at least 3 locations (typically at both ends and at any rail joint or in the middle); and
  - (v) for which, post-installation testing and periodic testing of the safety rail has provided evidence that the safety rail can withstand a static load test with a horizontal force of at least 3 kN load in at 3 locations (typically at both ends and at any rail joint or in the middle), where the load has been applied for at least 30 seconds. The periodic testing must be in accordance with the manufactures' recommendations or at least once every 5 years (whichever is less); and
- (e) windscreen wipers situated in front of the launch master that are effective in rough weather and a fixed system for applying fresh water to the area of the forward windows covered by the wipers.

NOTE Neither ISO 12401 nor AS 2227-2006 use a fall-arrest mechanism in their makeup that could extend the length of the tether during a fall, both do however seek to reduce the force on the occupant of the harness.

**Figure 11** — Pilot vessel uninterrupted, continuous safety rail system and clipping point illustration

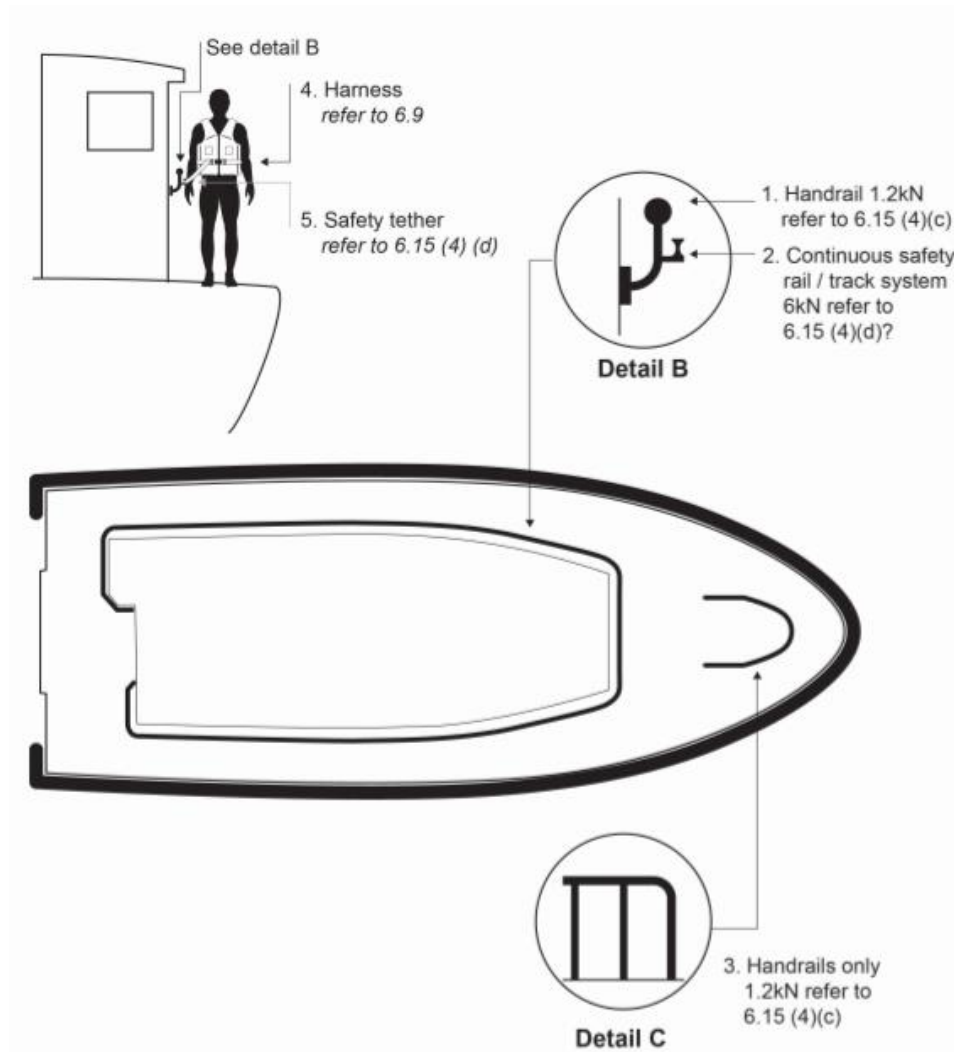



# **ANNEX A METHODOLOGY FOR DETERMINING THE MINIMUM REQUIRED AGGREGATE WIDTH OF DOORS, STAIRWAYS, CORRIDORS AND WALKWAYS SERVING A SPACE**

## **A1 Scope**

This Annex specifies the deemed-to-satisfy method for determining the minimum required aggregate width of doors, stairways, corridors and walkways serving a space.

## **A2 Application**

This Annex applies to escapes and evacuation paths on a vessel.

## **A3 Objective**

The objective of this Annex is to set out requirements that will facilitate:

- (a) the escape of all persons within a space from hazards that might arise within 5 minutes; and
- (b) the evacuation of all persons on a vessel into survival craft within 30 minutes from the issue of the order to abandon the vessel.

## **A4 Size of accessways**

The size of accessways must ensure that the calculated flow capacity of the accessway (clause A6) exceeds the required minimum flow of the accessway (clause A5).

## **A5 Required minimum flow through accessways**

The required minimum size of accessways must assume a time of passage of the first to the last person of 2 minutes and accommodate a flow of persons of a number determined as follows:

- (a) the number of persons accommodated within a space needing to use the access as an escape taking into account:
  - (i) the number of other similar accessways serving the space; and
  - (ii) the requirements for redundancy of flow capacity of escapes if there are more than 12 persons in the space; and
  - (iii) the contribution of any low-capacity escapes that may also be installed to serve the space; and
  - (iv) crew on duty that reduce the average number of persons in a crew accommodation space by one third; and
- (b) the number of persons needing to use the accessway as part of an evacuation path taking into account:

- (i) whether the path leads to an assembly station or directly to an embarkation station or whether it leads from an assembly station to an embarkation station; and
- (ii) the number of persons progressively entering the evacuation path from spaces along the evacuation path; and
- (iii) specified minimum widths for individual stairways, corridors, doors and walkways.

**A6 Calculated flow capacity of a single high-capacity accessway**

The calculated flow capacity of a single accessway used as a high-capacity escape or evacuation path is:

$$N_A = 0.12(W_{AN} - 300)$$

where:

$N_A$  is the number of persons passing through the accessway.

$W_{AN}$  is the nominal width of the accessway not counting narrowing due to hand railings, in metres.

The values in Table A1 have been derived from this formula and are for ascertaining the flow capacity of a single accessway.

**Table A1 — Calculated flow capacity of a single accessway**

Nominal width of single accessway (mm)	Calculated flow capacity (persons)
700	48
750	54
800	60
850	66
900	72
950	78
1000	84
1050	90
1100	96
1150	102
1200	108
1250	114
1300	120
1350	126
1400	132
1450	138

Nominal width of single accessway (mm)	Calculated flow capacity (persons)
1500	144
1550	150
1600	156
1650	162
1700	168
1750	174
1800	180
1850	186
1900	192
1950	198
2000	204
2100	216
2150	222
2200	228
2250	234
2300	240
2350	246
2400	252
2450	258
2500	264
2550	270
2600	276

NOTE Nominal width means the width of the accessway excluding any deduction from the intrusion of any handrails.

**A7 Person flow capacity for low-capacity escapes**

The deemed-to-satisfy person flow capacity of each low-capacity escape is 18 persons.

**A8 Required combined flow capacity of escapes from a space**

If a space is required to have more than 1 means of escape, the combined flow capacity of escapes serving the space is:

$$N_A^1 + N_A^2 + \dots + N_A^{N_E-1} \geq N_{PE}$$

where:

$N_A^1, N_A^2, \dots, N_A^{N_E}$  is the calculated flow capacity of each escape serving the space, in accordance with clause A6 if high capacity or clause A7 if low-capacity.

$N_A^1 + N_A^2 + \dots + N_A^{N_E-1}$  is the assumed number of persons within the space.

$N_{PE}$  is the assumed number of persons within the space.

The values given in Table A2 have been derived from this formula. They are valid assuming a space is served by equally sized high-capacity escapes without allowance for any low-capacity escapes.

- (a) As the number of persons in a space increases, the provision of just 2 means of escape becomes increasingly impracticable. The green shaded cells show the optimum configuration based on minimum total width of escapes from the space.
- (b) If low-capacity escapes also serve a space, the total number of persons assumed in the space may be reduced by 18 persons per low-capacity escape.

**Table A2 — Total nominal width of equally sized high-capacity door escapes serving a single space assuming no low-capacity escapes**

Number of persons in the space (see note 1)	Minimum total of the nominal widths of escapes serving the space (mm) (see notes 2 and 3)			
	2 exits	3 exits	4 exits	5 exits
72	1800	2700*	3600*	4500*
100	2267	2700*	3600*	4500*
125	2683	2700*	3600*	4500*
150	3100	2775	3600*	4500*
175	3517	3088	3600*	4500*
200	3933	3400	3600*	4500*
250	4767	4025	3978	4500*
300	5600	4650	4533	4625
350	6433	5275	5089	5146
400	7267	5900	5644	5667
450	8100	6525	6200	6188
500	8933	7150	6756	6708
550	9767	7775	7311	7229
600	10600	8400	7867	7750

Green cells indicate the preferred number of exist depending on the number of persons in the space.

\* Based on minimum 900 mm width of a door for each escape on a passenger vessel. Passageways would be at least 100 mm wider and stairways at least 200 mm wider due to the intrusion of handrails.

NOTE 1 Only be 67% of the crew needs to be accommodated within a crew accommodation space.

NOTE 2 Nominal width means the width of the accessway excluding any deduction from the intrusion of any handrails.

NOTE 3 The table assumes escapes are all the same size — a larger value will be required where the sizes of escapes differ from one another.

External Consultation Draft

## ANNEX B MARKING AND SIGNAGE

### B1 Scope

This Annex specifies the deemed-to-satisfy-solution for marking and signage required to articulate escape and evacuation paths on smaller less complex lower risk vessels.

### B2 Application

This Annex applies to the marking and signage of escapes and evacuation paths on:

- (a) All vessels with up to 12 passengers.

### B3 Objective

The objective of this Annex is to set out requirements for the adequate marking and signage of escape and evacuation:

- (a) the marking and signage must be readily understood by the majority of passengers and crew within 60 seconds.
- (b) aid in the supply of rapid evacuation and escape of all persons on a vessel to a muster station or survival craft by supplying adequate graphical instructions and identifying paths and equipment.

### B4 General requirements

- 1) Signs and markings must be the minimum following sizes set out in Table B1 and pictorially the same or equivalent to figure B1.
- 2) Alternatively, compliance with the *ISO 24409* series of standards, *IMO Resolution A.1116(30)* or *AS1319, Safety Signs for the Occupational Environment* is a deemed to satisfy solution.
- 3) Must be maintained, serviced, and replaced in accordance with manufacturers recommendations.

**Table B1 – Size of signs and markings**

Vessel length	Square shape (minimum size)	Rectangle shape (minimum size)	Colour
<12m	100mm x 100mm	80mm x 150mm	White symbol or worded legend, or both, on a green rectangle or square with white enclosure. Signs must be either. <ul style="list-style-type: none"> <li>a) Photoluminescent marking (minimum luminance of 30 mcd/m<sup>2</sup> for not less than 90 minutes)</li> <li>b) Non-Photoluminescents but marked by a lighting source capable of supply for 90 minutes in an emergency.</li> </ul>
≥12m to <24m	150mm x 150mm	150mm x 300mm	
≥24m	300mm x 300mm		

NOTE Vessels that carry more than 12 passengers are higher risk vessels which require compliance with clause 5.16(4).

**Figure B1 Exit and escape signs**



**NOTE 1** Photoluminescent signs have different ratings for indoor and outdoor use and different service and replacement intervals depending on the rating/quality of the sign/marking.

**NOTE 2** That your vessel situation maybe not be represented by the limited examples above and other similar derivatives can be used. The table B1 size requirements must be maintained.